

MACH-Pro2™

Building Controller

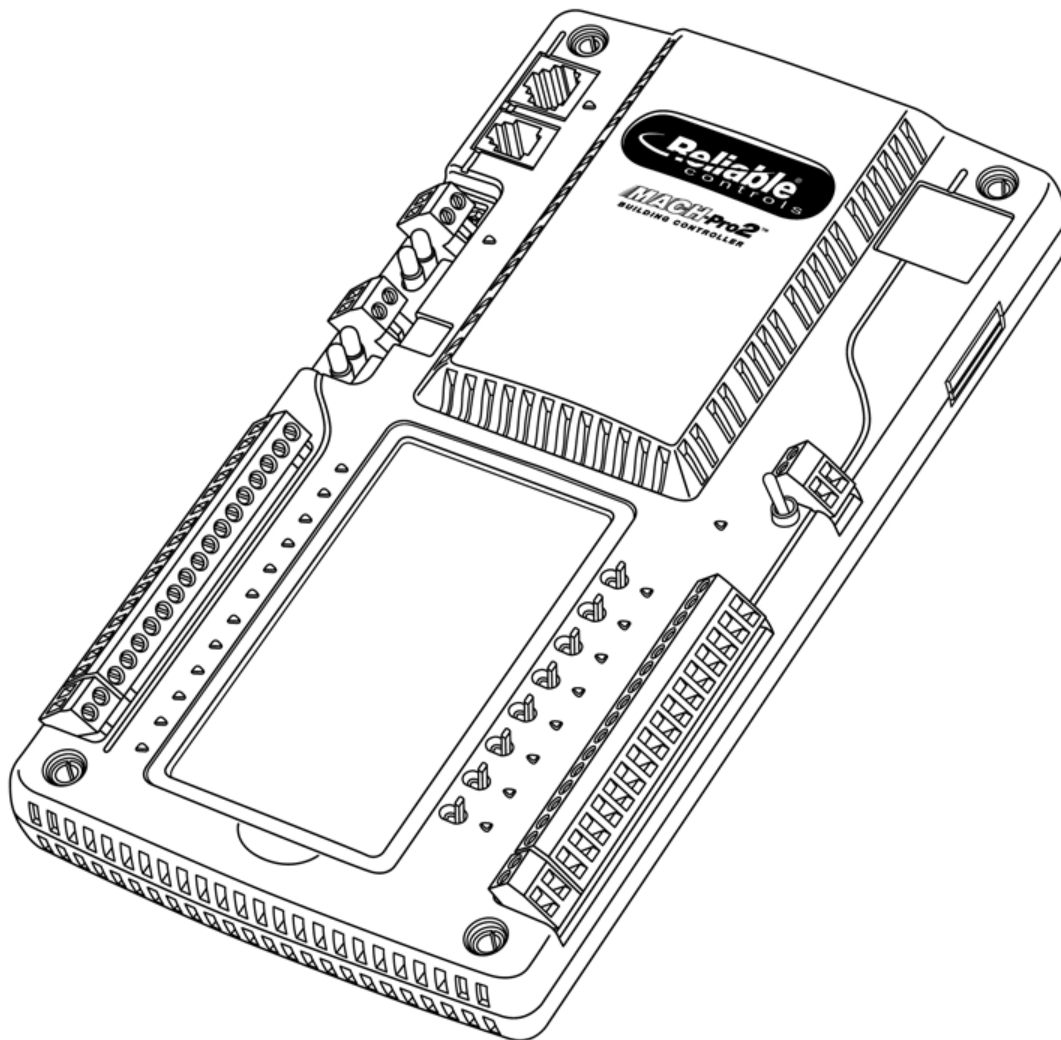

Better by design™

User Guide

Reliable[®]
controls

© 2000-2025 Reliable Controls® Corporation. All rights reserved.

This manual is for information purposes only. The contents and products described are subject to change without notice. Reliable Controls Corporation makes no representation with respect to this manual. In no event shall Reliable Controls Corporation be liable for damages, direct or incidental, arising out of or related to the use of this manual. Parts of this document may not be reproduced or transmitted in any form or by any means, without the express written permission of Reliable Controls Corporation.

Reliable Controls® Corporation

120 Hallowell Road

Victoria, BC, V9A 7K2

Phone 1-250-475-2036

Toll-Free: 877-475-9301 (US & Canada Only)

Fax: 250-475-2096

Email: info@reliablecontrols.com

reliablecontrols.com

Reliable Controls, myControl, RC-Archive, RC-FLEXair, RC-FLEXone, RC-GrafxSet, RC-Hospitality, RC-LicenseManager, RC-Passport, RC-RemoteAccess, RC-Reporter, RC-Studio, RC-Toolkit, and RC-WebView are registered trademarks of Reliable Controls Corporation.

BACnet is a registered trademark of ASHRAE.

FlexTile, MACH1, MACH2, MACH-Air, MACH-CheckPoint, MACH-Global, MACH-Pro1, MACH-Pro2, MACH-ProAir, MACH-ProCom, MACH-ProLight, MACH-ProPoint, MACH-ProSys, MACH-ProView, MACH-ProWeb, MACH-ProWebCom, MACH-ProWebSys, MACH-ProZone, MACH-Sentry, MACH-Stat, MACH-System, MACH-Zone, RC-FLEXlink, SMART-Sensor, SMART-Net, SMART-Space, and SPACE-Sensor are trademarks of Reliable Controls Corporation.



Contents

MACH-Pro2 overview	5
MACH-Pro2 features	5
MACH-Pro2 models and accessories	7
Standard applications	8
Applications	9
MACH-Pro2 hardware overview	11
Additional resources	12
MACH-Pro2 installation and wiring	14
Installation considerations	14
MACH-Pro2 power	14
Grounded power	14
Status LED for MACH-Pro controllers	15
PC/Modem Direct Connect or modem connections	15
EIA-232 serial port communications	17
EIA-232 status LED	18
PC/Modem port pinout	18
EIA-485 serial port communications	19
EIA-485 wiring for grounded controllers	20
End-of-Line switch	21
MS/TP-Net status LED and network protection	21
SMART-Net on a MACH-Pro series controller	22
SMART-Net RJ11	22
MACH-Pro2 inputs	23
Input jumpers	24
Set the input jumpers	24
Inputs	25
Input LEDs for MACH-Pro controllers	27
MACH-Pro2 outputs	27
Universal outputs	28
Output override potentiometer	29
Adjust the output voltage	30
Hand/Off/Auto (HOA) switches	30
Output LEDs	31
Peripheral power supply	31

Adjust the peripheral power supply voltage	32
Inputs and outputs label	32
Configuration	33
RC-Toolkit and your controller	33
Default MS/TP settings	33
Default PC/Modem settings	33
Default user access settings	33
Connect using Direct Connect (PC/Modem)	34
Connect to the controller's RJ11 SMART-Net port using an X-Port-2 Converter	34
Configure communications using the RC-Toolkit MSet tool	35
Enable X-Port-2 Converter access over SMART-Net	36
MACH-Pro1/MACH-Pro2 MSet configuration	37
Baud rate configuration	41
Default MS/TP settings	42
Reset button operation	43
Controller database	44
RC-Studio and your controller	44
Point Status BACnet property	44
Net Ins and Net Outs BACnet properties	45
Object instance BACnet property	46
Supported Control-BASIC	46
Specifications	49
MACH-Pro2 technical specifications	49
I/O-Net communications for MACH-ProPoint	52
MACH-ProPoint expansion module wiring	52
MACH-ProPoint I/O-Net address	53
I/O-Net status LEDs and network protection	53
MACH-ProPoint host I/O-Net configuration	54
Add MACH-ProPoint expansion modules to the host controller	54
MACH-ProPoint host database configuration	55
MACH-ProPoint expansion modules in RC-Studio	55
Identify connected MACH-ProPoint modules	56
I/O-Net lost connection behavior	56

MACH-Pro2 overview

Designed to be an expandable workhorse of the industry, the Reliable Controls MACH-Pro2™ is a rugged, flexible, fully programmable BACnet Building Controller (B-BC) ideal for large rooftop equipment or midsize mechanical room applications.

MACH-Pro2 features

For the most complete, up-to-date information, click your product on the [Products](#) page to access the submittal sheet.

Protocols

- BACnet.
 - MS/TP and PTP.

12 Inputs

- Universal ranges.
- Use a jumper to select thermistor/dry contact, 4–20 mA, or 0–10 VDC.
- Add up to three MACH-ProPoint expansion modules to accommodate up to 72 additional inputs.

Eight Outputs

- Universal ranges.
- Optional Hand/Off/Auto (HOA) switches with position feedback to RC-Studio®.
- Add up to three MACH-ProPoint™ expansion modules to accommodate up to 56 additional outputs.

512 Values

- Select standard and custom ranges as well as fixed program-driven values.

64 Loops

- Standard P, PI, or PID controllers for closed loop control.

32 Schedules

- Up to 7 on/off cycles for each weekday or exception.

64 Calendars

- Designate days of the year as holidays.

20 Tables

- For creating custom scaling functions.

64 System Groups

- Group related objects on one display.
- 160 objects per group.

64 Programs

- Freely programmable control strategy in a readable, BASIC-like language.
- 3,200 bytes per program.

Multipoint Trend Logs

- Store up to eight objects in each trend log.
- Record values at user-defined intervals.
- Dynamic; user assigned.

Single-point Trend Logs

- Record values user-defined intervals or based on change of value.
- Dynamic; user assigned.

Runtime Report

- Total the on time and record the on/off times of every binary object.
- Automatically generated.

128 Arrays

- Up to 128 elements in a one-dimensional array.

128 User Passwords

- Protect access to the system.
- Assign each user with a username and access level.
- Multiple levels of security.

24 Custom Units

- Eight analog engineering units.
- Eight binary units.
- Eight multistate units with eight states.

SMART-Net Port

- Network up to 16 SMART-Sensor devices.

256 Net Ins

- The maximum number of shares from other devices.

128 Net Outs

- The maximum number of writes to other devices.

Real-Time Clock

Warranty

- 5 years.

MACH-Pro2 models and accessories

For the most complete, up-to-date information, click your product on the [Products](#) page to access the submittal sheet.

MP2

- MACH-Pro2.

Options

- -H adds HOA switches.

Build Your Order

To create the order number, add your options to the base model. For example, MP2-H is the order number for a MACH-Pro2 with HOA switches.

Accessories

MP-DINRAIL

- Two-piece adapter kit to mount controller on a 35 mm x 7.5 mm top hat DIN rail. DIN rail not included.

MP-DINRAIL

- Two-piece adapter kit to mount controller on a 35 mm x 7.5 mm top hat DIN rail. DIN rail not included.

MPP-IO

- MACH-ProPoint Input/Output expansion module.

MPP-IO-H

- MACH-ProPoint Input/Output expansion module with HOA switches.

MPP-IO-U

- MACH-ProPoint Input/Output Universal expansion module.

MPP-IO-U-H

- MACH-ProPoint Input/Output Universal expansion module with HOA switches.

MPP-IO-DL-LASER

- MACH-ProPoint Input/Output expansion module door label sheet for laser printer.

MPP-IO-DL-INKJET

- MACH-ProPoint Input/Output expansion module door label sheet for inkjet printer.

MPP-I

- MACH-ProPoint Input expansion module.

MPP-I-B

- MACH-ProPoint Binary Input expansion module.

MPP-I-DL-LASER

- MACH-ProPoint Input expansion module door label sheet for laser printer.

MPP-I-DL-INKJET

- MACH-ProPoint Input expansion module door label sheet for inkjet printer.

MPP-O

- MACH-ProPoint Output expansion module.

MPP-O-H

- MACH-ProPoint Output expansion module with HOA switches.

MPP-O-DL-LASER

- MACH-ProPoint Output expansion module door label sheet for laser printer.

MPP-O-DL-INKJET

- MACH-ProPoint Output expansion module door label sheet for inkjet printer.

RM

- Package of 10 relay output modules.

TM

- Package of 10 TRIAC output modules.

UM

- Package of 10 universal output modules.

SS-RJ11TB-B

- RJ11 to six-pole terminal block base.

SS-RJ11TB-C

- RJ11 to six-pole terminal block cable; 30 cm (1 ft).

SNX

- SMART-Net Expansion Board.

SSX

- SMART-Sensor Expansion Board.

Standard applications

Standard applications for Reliable Controls products are available in the Engineer tab in the Reliable Controls Support Center.

Each standard application contains the elements needed to deploy an application, such as:

- Control-BASIC code.
- Panel Files.
- System Groups.
- Annotated sequences of operation.

Standard applications also serve as useful learning tools to increase your knowledge of different product applications and Control-BASIC programming.

Search the library of existing standard applications or use the Standard App Builder to find a standard application that meets your selection criteria. If you cannot find a standard application that suits your needs in the Standard App Builder, click the **Submit a request** button to request it.

Download and install the standard application and modify for your implementation.

Applications

The MACH-Pro2 can be incorporated into different building control and communications network applications. The following diagram illustrates how to connect other components to the MACH-Pro2. A network of up to 8 SMART devices can be hosted on the SMART-Net port to extend the controller's sensors and provide user input as well as a connection for initial configuration of the controller. The I/O-Net port supports up to 3 MACH-ProPoint expansion modules to provide additional inputs and outputs. A workstation running Reliable Controls software such as RC-Studio or RC-Toolkit can be connected using the BACnet direct connection to the controller's PC/Modem port to configure the controller or view and edit System Groups and other information.

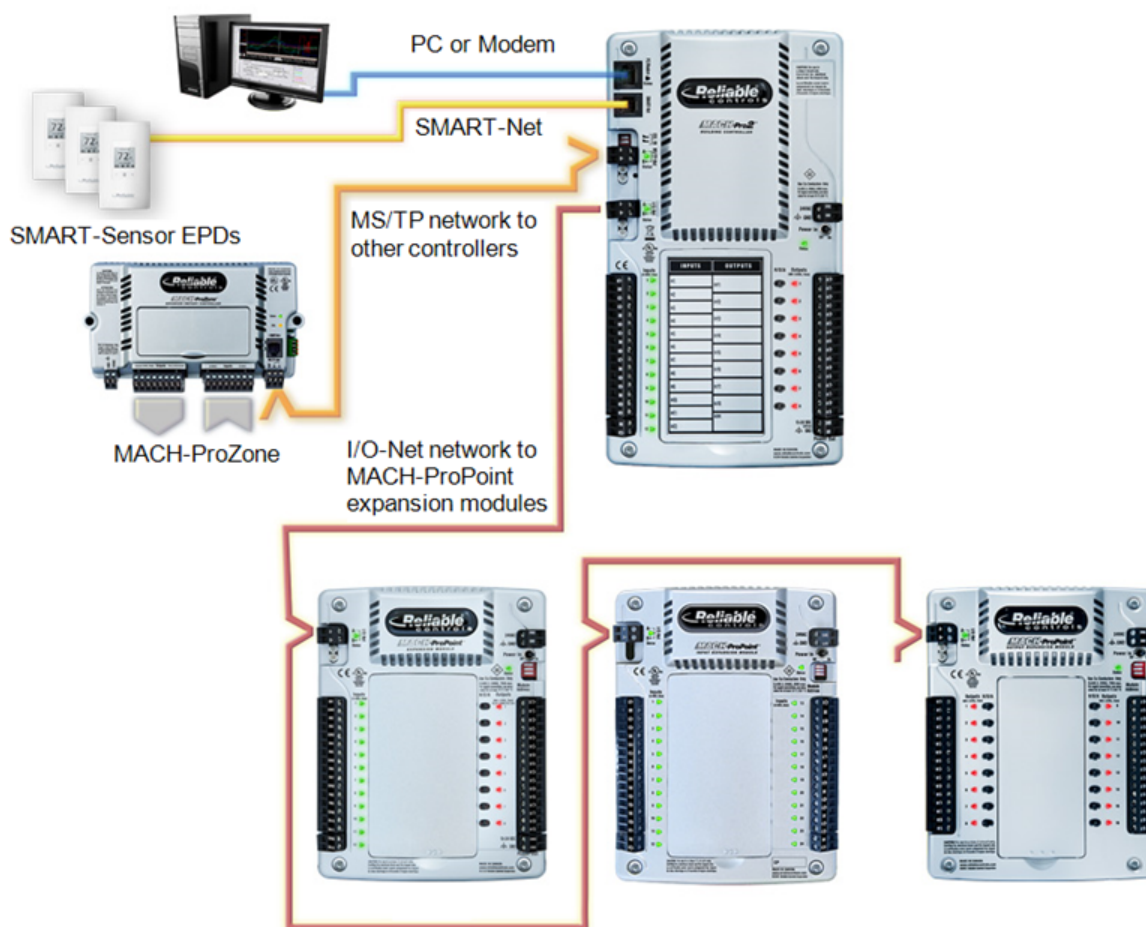

Figure 1: MACH-Pro2 network diagram.

Additional BACnet controllers and devices are connected to the MS/TP network hosted from the MS/TP-Net port.

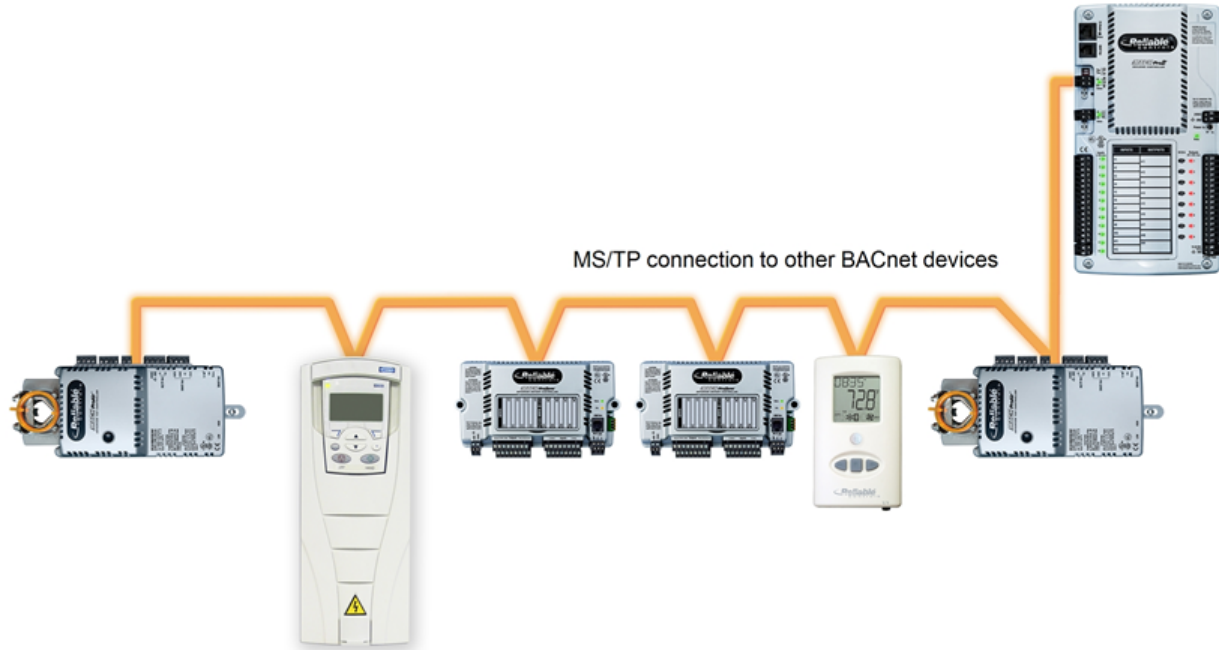

Figure 2: MACH-Pro1 hosting other devices through the MS/TP-Net port connections.

MACH-Pro2 hardware overview

Install the MACH-Pro2 by connecting power, communications, and inputs and outputs.

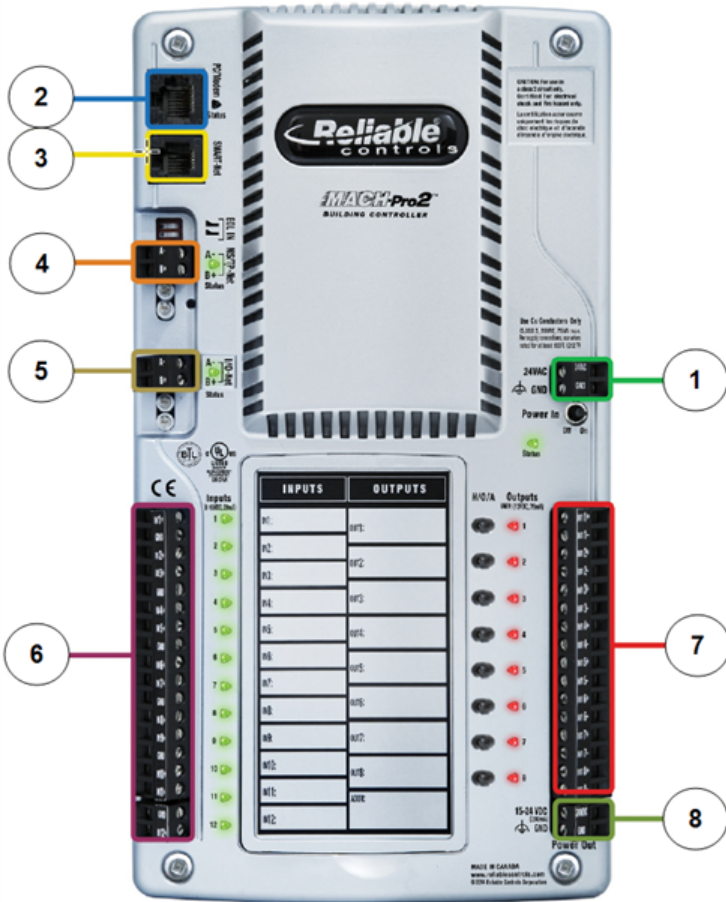

Figure 3: MACH-Pro2 connections.

- ① Power with toggle switch
- ② EIA-232 PC/Modem port
- ③ SMART-Net
- ④ EIA-485 MS/TP-Net with End-of-Line (EOL) switches, LED, and network protection bulbs
- ⑤ EIA-485 I/O-Net port with LED and network protection bulbs
- ⑥ Inputs with input LEDs
- ⑦ Outputs with output LEDs and optional HOA (Hand/Off/Auto) switches
- ⑧ Peripheral DC power supply

Additional resources

Additional resources are available on the [Reliable Controls Support Center](#).

Click any of the following in the menu bar:

Products

View all product documentation, manuals, and marketing material.

Technical

View Release Notes, Bulletins, Product and Security Alerts, and the DDC (Direct Digital Control)

Glossary.

eHelpDesk

Click the eHelpDesk link in the Support Center banner and search or browse solutions, application support articles, and the community forum, or create a support ticket to connect with an agent.

Training

Use the Learning Center to view and register for training courses, access eLearning courses and videos, view webcasts, and download manuals.

MACH-Pro2 installation and wiring

This section describes the controller's connections as well as the overall installation and wiring process and important considerations.

Installation considerations

All Reliable Controls devices must be installed in accordance with the National Electrical Code (NFPA 70), the Canadian Electric Code Part 1 (CSA C22.1-12), or the International Electrical Code (IEC 60730-1) as applicable and in a manner acceptable to the local authority having jurisdiction.

This device is for use in UL Class 2 and Class 3 ELV circuits only.

Follow these guidelines when you install Reliable Controls products:

- Ground yourself before you touch any electronics by touching a grounded metal surface to discharge static electricity.
- Use copper conductors only.
- Ensure that field wires are securely fastened in the terminal blocks by firmly tightening the screws.
- Ensure that terminal blocks are completely inserted and firmly seated.

MACH-Pro2 power

The MACH-Pro2 requires external power.

Supply Voltages

- 24 VAC \pm 10%, 75 VA maximum, 50/60 Hz.
- 24 VDC \pm 10% 26 W maximum.

Wiring Terminals

- 12–22 AWG (3.31–0.33 mm²).
- Stranded or solid core.
- Copper conductors only.

Grounded power

Follow these guidelines when you select and wire the grounded power supply:

- Use a UL Class 2 or Class 3 ELV 24 VAC/VDC power supply for the controller.
- Ensure that all controllers are connected to earth ground.
- Use the power calculator at reliablecontrols.com/support/engineer/calculator.php to determine the size of the AC transformer or DC power supply required for your installation.

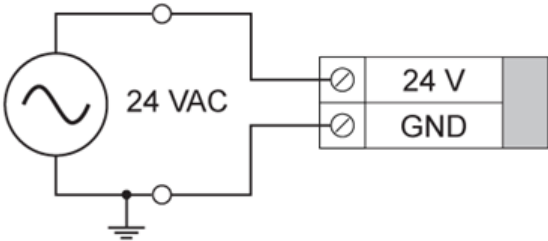

Figure 4: 24 VAC grounded power supply wiring

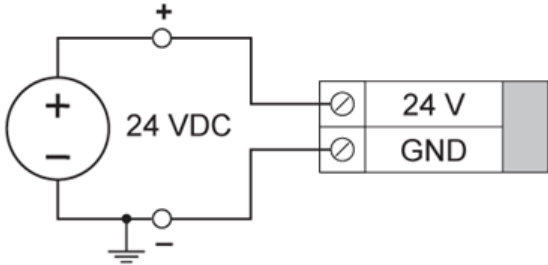

Figure 5: 24 VDC grounded power supply wiring

Status LED for MACH-Pro controllers

The controller status LED is located near the power switch.

The status LED indicates the controller's status as follows:

Status LED	Status
One flash per second	Normal operation.
Flicker	OS Send operation in progress. Do not remove power.
On solid/off solid	No operation. Defective controller.

PC/Modem Direct Connect or modem connections

The PC/Modem port supports EIA-232 serial communications. Use the controller's PC/Modem port to connect directly to a computer, or to provide remote communications through an external modem.

Reliable Controls assembles and stocks factory-tested cables, connectors, converters, and modems for EIA-232 connections, available to purchase in eBusiness:

- **CC-C1-C:** Computer cable with RJ45 male ends. Use CC-CABLE-BUILDER to specify cable length.
- **CC-C1-B:** Cable base adapter with RJ45 socket and DB9 female connector.
- **CNV-USB-232:** USB Type A Converter for Universal Serial Bus to EIA-232 (DB9 male connector).
- **CNV-USB-232-C:** USB Type C Converter for Universal Serial Bus to EIA-232 (DB9 male connector).

EIA-232 serial direct connection

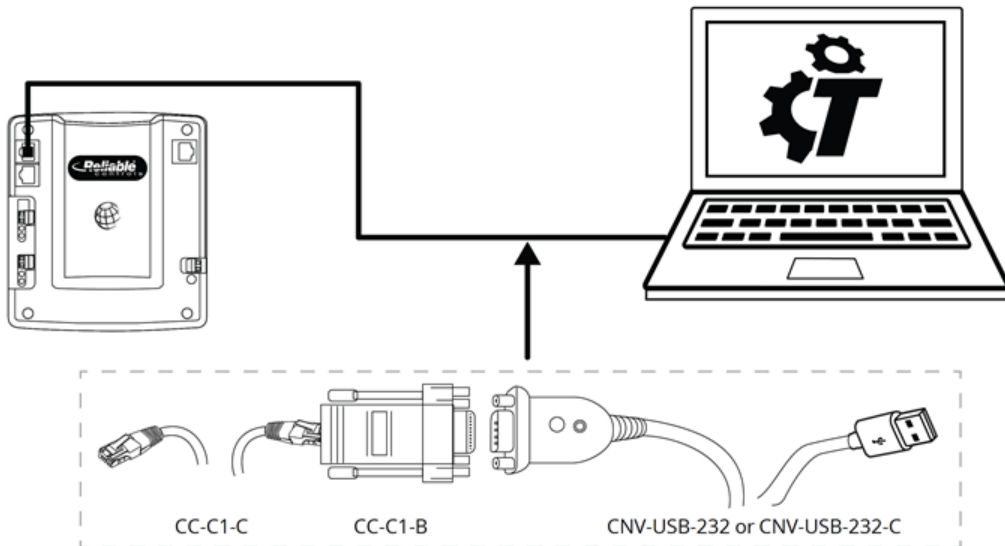

1. Connect one end of the CC-C1-C cable to the controller PC/Modem port.
2. Connect the other end of the cable to the CC-C1-B cable base.
3. Connect the appropriate USB-to-232 converter to the CC-C1-B cable base:
 - If the computer has USB-A ports, use CNV-USB-232
 - If the computer has USB-C ports, use CNV-USB-232-C
4. Connect the converter's USB connector to the computer USB port.

Refer to the RC-Toolkit documentation for instructions on Direct Connect serial connection.

EIA-232 remote modem connection

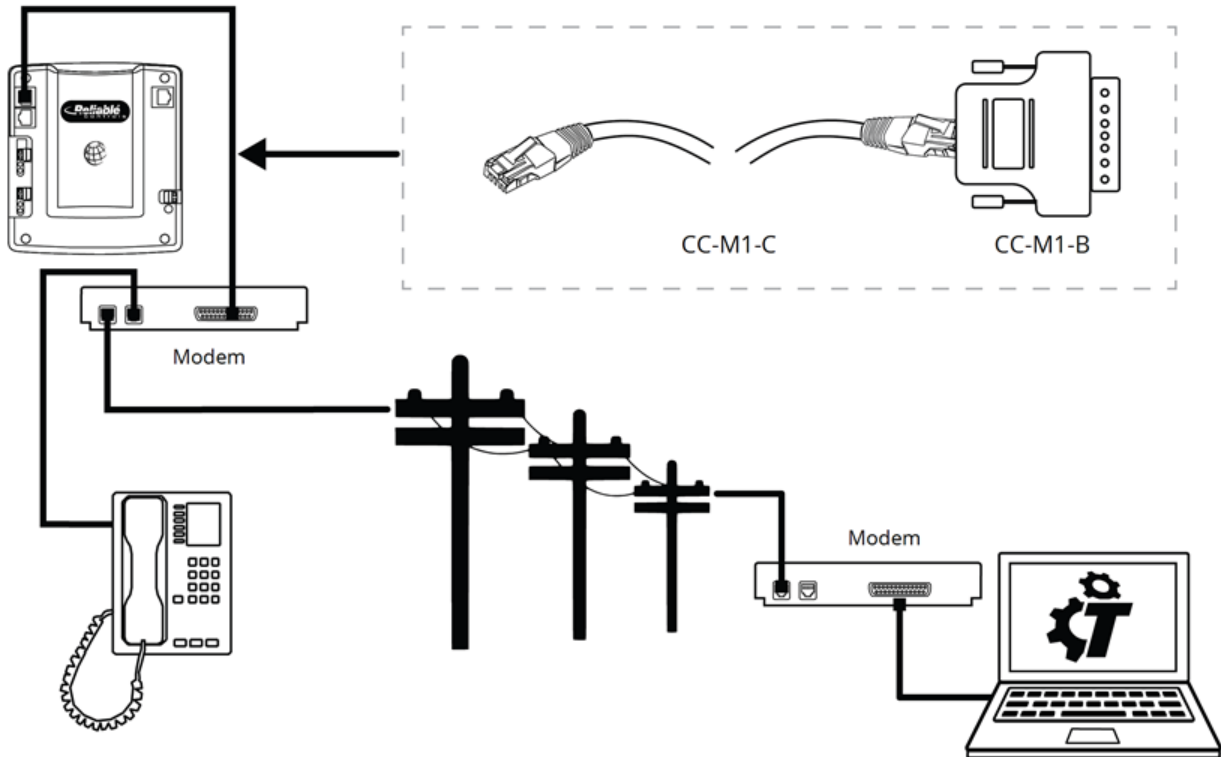

Important: The modem connected to the controller must be purchased from Reliable Controls.

These are available to purchase in eBusiness:

- **CC-M1-C:** Modem cable with RJ45 male ends. Use CC-CABLE-BUILDER to specify cable length.
- **CC-M1-B:** Cable base adapter with RJ45 socket and DB25 male connector.
- **MODEM:** External modem, configured and tested.

1. Connect one end of the CC-M1-C cable to the controller PC/Modem port.
2. Connect the other end of the cable to the CC-M1-B cable base.
3. Connect the CC-M1-B cable base to the modem's DB25 connector.
4. Connect the modem phone jack to the wall jack.

Refer to the RC-Toolkit documentation for instructions on remote modem connection.

EIA-232 serial port communications

The controller has a PC/Modem port for direct serial EIA-232 connections. EIA-232 is a point-to-point serial communications connection method used to connect one node to another node. EIA-232 is used to make a direct connection between a computer and the controller, or for point-to-point communications with a third-party BACnet device.

The maximum recommended distance between EIA-232 nodes is 15 m (50 ft).

The PC/Modem port is a standard 8P8C RJ45 jack. Refer to the "PC/Modem port pinout" topic for connection details for each pin.

EIA-232 status LED

The controller has an EIA-232 status LED located near the PC/Modem port.

The EIA-232 status LED indicates the controller's EIA-232 communications status as follows:

- **Flicker:** Normal operation. The LED flickers to indicate transmit and receive activity.
- **Flashing with the controller status LED:** EIA-232 baud rate error.
- **Six flashes/second:** Self-test. If flashing persists after you power up the controller, the self test failed.

PC/Modem port pinout

The PC/Modem port is a standard RJ45 jack, with its eight position, eight contact (8P8C) pinout defined with respect to the controller. The required pin connections for modem communications, or for direct EIA-232 communications connection to a computer, are defined in the pinout table below.

The controller's PC/Modem port pinout:

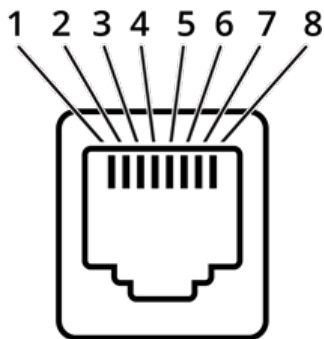

Pin	PC/Modem port	Connect to modem	Connect to PC (Direct Connect)
1	Shield	Shield	No connect
2	Ground	Ground	Ground
3	Receive data (RX)	Transmit data (TX)	Transmit data (TX)
4	Data terminal ready (DTR)	Data set ready (DSR)	No connect
5	Carrier detect	Carrier detect	No connect
6	Request to send (RTS)	Clear to send (CTS)	No connect
7	Clear to send (CTS)	Request to send (RTS)	No connect
8	Transmit data (TX)	Receive data (RX)	Receive data (RX)

EIA-232 cabling

If you make your own cable for the modem connection or for direct connection to the computer serial port, use a good-quality four-pair, unshielded twisted-pair (UTP) Category 5 (Cat 5), Category 5 enhanced (Cat 5e), or Category 6 (Cat 6) cable. Use Plenum-rated cables as required.

EIA-485 serial port communications

The controller's EIA-485 ports are labeled. The label indicates what functions and supported communications protocols are supported.

MS/TP-Net: This port supports the BACnet protocol.

- Maximum EIA-485 segment length: 1,220 m (4,000 ft).

I/O-Net: This port supports the I/O-Net protocol, to communicate with and control connected MACH-ProPoint expansion modules.

- Maximum I/O-Net segment length: 152 m (500 ft).

Wiring Terminals

- 12–22 AWG (3.31–0.33 mm²).
- Stranded or solid core.
- Copper conductors only.

The controller's EIA-485 connections are protected with replaceable EIA-485 network protection bulbs.

EIA-485 wiring for grounded controllers

The grounded controller's EIA-485 port is a two- or three-pole terminal block used for BACnet MS/TP communication. The EIA-485 transceiver is non-isolated and internally references the controller's power ground. The ground connection helps keep all networked devices at the same reference to each other which works to improve communications by making sure that signals are at the same level at all nodes throughout a distributed system.

All devices on the same EIA-485 network must communicate using the same protocol and baud rate, and each node must have a unique address. EIA-485 devices are connected using a line topology.

Note: Maximum EIA-485 segment length: 1,220 m (4,000 ft).

The grounded controller's EIA-485 terminal block has either two terminals: A(-) and B(+), or three terminals: A(-), B(+), and REF. To connect multiple grounded controllers, use the EIA-485 connector to wire terminal A(-) to A(-), and B(+) to B(+). Connect the bare shield wires at each junction to help suppress noise along the cable length.

The REF terminal is internally connected to the controller's power ground and can be used to connect isolated devices that use a three-wire MS/TP network.

Installation guidelines:

- Use a good quality, low-impedance, twisted two-conductor shielded communications cable with capacitance less than 82 pF/m (25 pF/ft).
- EIA-485 cable shields should be continuous, electrically connected, and grounded at one end only.
- End-of-Line (EOL) must be set to on for the two devices located at the physical extremities.
- REF terminal is intended to connect isolated devices that use a three-wire MS/TP network.

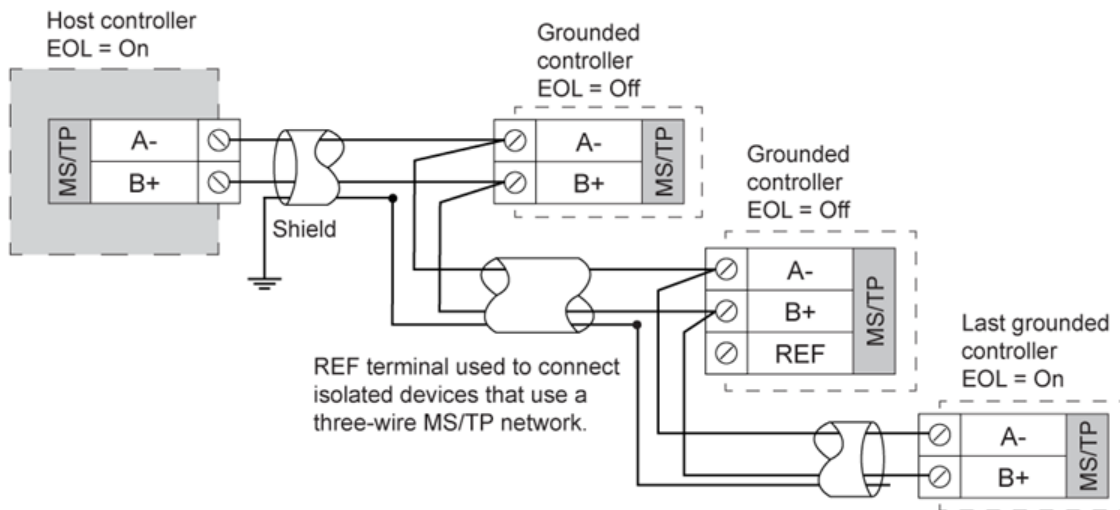

Figure 6: EIA-485 wiring for grounded controllers

End-of-Line switch

The End-of-Line (EOL) switch must be set to on for the two devices located at the physical extremities of each separate EIA-485 network.

Each EIA-485 network can have only two EOL terminations. EOL switches prevent reflected noise and bring network voltage to a known value if communications are idle. If the network is not terminated correctly, the controller may fail to network properly. If the EOL device is not a Reliable Controls controller, you can add an NA-EOL terminator, available in eBusiness in the Reliable Controls Support Center.

To maintain EIA-485 network integrity, use only Reliable Controls EOL switches or terminators.

MS/TP-Net status LED and network protection

The MS/TP-Net port supports BACnet communications. The MS/TP-Net port LED provides the following network status information.

- **Flashing:** Normal EIA-485 communication. The LED is on when the controller has the token.
- **Flashing with the controller's status LED:** Baud rate error or the A- and B+ wires are crossed.
- **On:** No EIA-485 communication. The controller is holding the token.

EIA-485 network protection

The device uses network protection bulbs to protect the EIA-485 port from issues such as ground reference difference or a miswired power connection.

The bulbs light up and remain lit until the issue is resolved.

Replacement network protection bulbs are available for order as Reliable Controls part number NA-BULB.

SMART-Net on a MACH-Pro series controller

The MACH-Pro series controller has a SMART-Net port that can host a network of up to 16 SMART-Net devices.

The maximum tested SMART-Net cable length from the host controller to the last SMART-Net device on the SMART-Net bus is 45 m (147 ft). With an externally powered SMART-Net Expansion Board or SMART-Sensor Expansion Board located at the network midpoint, the maximum tested SMART-Net cable length from the host controller to the last SMART-Net device on the SMART-Net bus is 75 m (246 ft).

Wiring Terminals

- 12–22 AWG (3.31 mm² to 0.33 mm²).
- Stranded or solid core.
- Copper conductors only.

SMART-Net RJ11

The SMART-Net RJ11 port supports a network of SMART-Sensor devices and MS/TP communications.

The SMART-Net network provides power and communications for SMART-Sensor devices. Reliable Controls recommends using 24 AWG (0.20 mm²) solid-core Category 3 or Category 5 cabling for SMART-Net networks.

Note: The maximum tested SMART-Net cable length from the host controller to the last SMART-Net device on the SMART-Net bus is 45 m (147 ft). With an externally powered SMART-Net Expansion Board or SMART-Sensor Expansion Board located at the network midpoint, the maximum tested SMART-Net cable length from the host controller to the last SMART-Net device on the SMART-Net bus is 75 m (246 ft).

Use the 6P6C (RJ11) modular connector port as one physical extremity of a SMART-Net network.

RJ11 terminals

Note: RJ11 connectors for stranded and solid-core conductors are not interchangeable. Using the wrong connector for the conductor causes intermittent communication. Connectors for solid-core conductors have a single jaw that wraps around the solid conductor. Connectors for stranded conductors, which are not the recommended conductor type, have teeth on the gold plates that pierce the wire.

SMART-Net uses four conductors to provide power and serve as the physical layer for SMART-Net communication between the host controller and connected SMART-Sensor devices. Use two additional conductors to extend the MS/TP controller-level communication network and provide field-level workstation access. The following image shows these conductors.

Note: Extending the MS/TP network can create noise, reflections, and other communication issues.

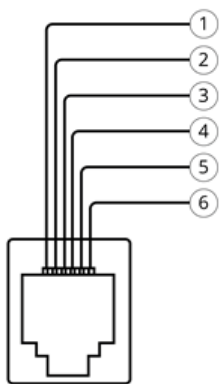

Figure 7: SMART-Net RJ11 terminals

Table 1: SMART-Net terminals

Pin	Controller RJ11 port	SMART-Net device RJ11 port	EIA-485
1	Clock	Data	N/A
2	+5 V	Ground	N/A
3	MS/TP A(-)	N/A	MS/TP A(-)
4	MS/TP B(+)	N/A	MS/TP B(+)
5	Ground	+5 V	N/A
6	Data	Clock	N/A

For detailed information about SMART-Net networks, sensors, and controllers, refer to the SMART-Net device documentation available on the [Reliable Controls Dealer Support Center](#).

MACH-Pro2 inputs

The MACH-Pro2 has universal inputs.

Universal Inputs

- 12 universal inputs.
- 12-bit A/D converter.
- Analog: 0–10 VDC, 4–20 mA, thermistor.
- Binary: Dry contact.
- Impedance:
 - 1 M Ω for 0–10 VDC range.
 - 250 Ω for 4–20 mA range.
 - 20 k Ω pull-up for thermistor/dry contact range.

- Pulse counting up to 150 Hz. Supports flow meters.
- 24 VAC overvoltage protection.

Wiring Terminals

- 12–22 AWG (3.31–0.33 mm²).
- Stranded or solid core.
- Copper conductors only.

Input jumpers

Input jumpers are used to set the universal inputs to correctly receive information from these input types:

- 0–10 VDC field device
- Thermistor/dry-contact
- 4–20 mA field device

Set the input jumpers

Use the input jumper to set the universal input type to match the connected field device or sensor:

1. Remove the detachable plastic door to access the internal circuit board.
2. Identify the input jumper that corresponds to the input you want to set.
3. Set the input jumper to the desired input type. Refer to the protector director on the circuit board for the jumper placement.
4. Reattach the plastic door.



- ① Voltage (0-5 VDC / 0-10 VDC)
- ② Thermistor / dry-contact
- ③ Current (4-20 mA)

Tip: If you are not using the jumper, secure it to a single pin to prevent it from being lost.

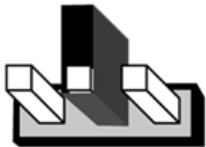

Figure 8: Jumper attached to single pin

Inputs

The controller has universal inputs where the type of input is determined by a hardware jumper.

The controller uses two terminal designations for inputs, labeled INx and GND , where x is the input instance or identifier, for example IN1, IN2, IN3, etc.

Since all input GND terminals are internally common to the power terminal block GND pole, common/ground jumpers are not required.

Note: Analog inputs promptly detect faults when you set the D column in the Inputs worksheet to Y, or decommissioned; otherwise, fault detection is slightly delayed to help prevent false alarms caused when a user presses a button on a connected SPACE-Sensor Temperature.

The following schematics show the wiring for dry contact, thermistor, voltage, and current input types:

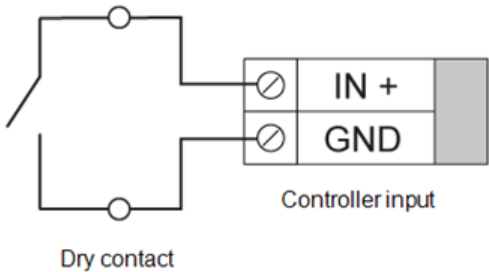

Figure 9: Dry contact input wiring

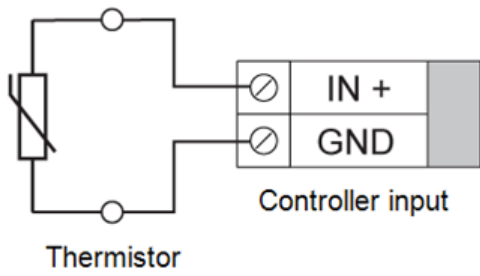

Figure 10: Thermistor input wiring

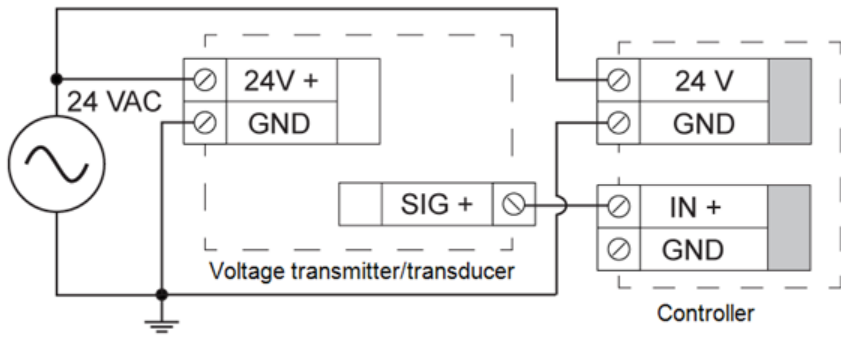

Figure 11: Voltage input wiring

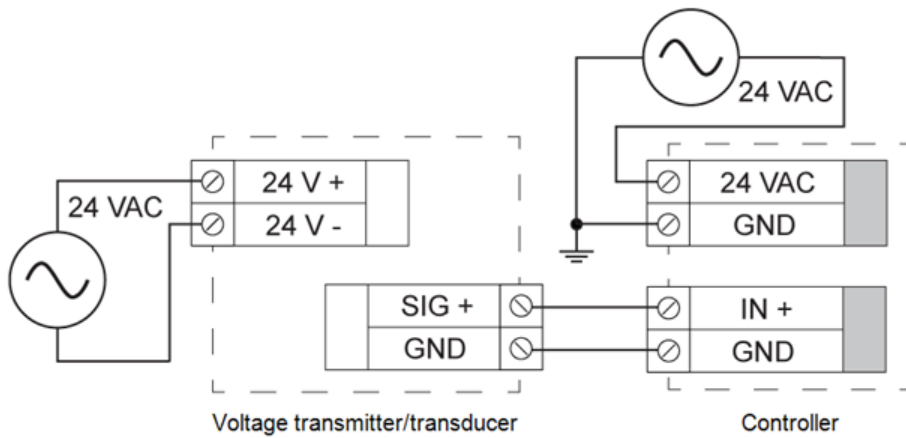

Figure 12: Voltage input wiring, four-wire

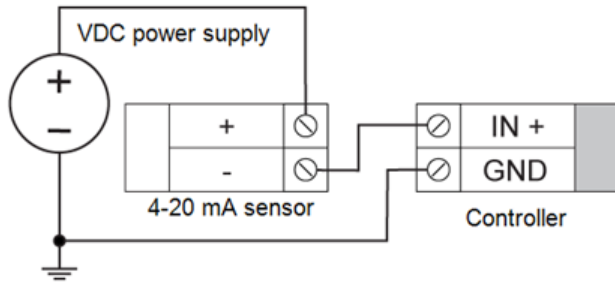

Figure 13: Current input wiring

Note: 4–20 mA loop-powered sensors require a DC voltage power supply to operate. The controller converts this input to a 1-5 VDC signal. If you scale this input in RC-Studio, the input range of the table is 1-5 VDC.

Input LEDs for MACH-Pro controllers

Inputs have LEDs that indicate the input type and value. Input LED brightness varies based on input type.

The input LED brightness increases with the voltage potential between the input and ground or common. If the potential is zero, the LED is off. At maximum potential the LED is at its brightest, and the LED brightness varies between those two states based on the input type:

Dry-contact

LED off = input closed. LED on = input open.

Thermistor

LED brightness increases as input resistance increases. Resistance decreases as temperature increases for negative temperature coefficient (NTC) thermistors.

Voltage

LED brightness increases as input voltage increases and dims as voltage decreases over the range of 0 to 10 VDC.

Current

LED brightness increases as input current increases and dims as current decreases over the range of 4 to 20 mA.

MACH-Pro2 outputs

The MACH-Pro2 has universal outputs.

Each output has an output status LED, a manual override potentiometer and an optional Hand/Off/Auto (HOA) switch.

Universal Outputs

- 12-bit D/A converter.
- Analog: 0–12 VDC.
- Binary: Software-configurable between 0–12 VDC.
- Manual on provides adjustable 0–12 VDC on controller with HOA option.
- LED indicator glows proportionally.
- Maximum 75 mA each.
- 24 VAC overvoltage and short protection.

Wiring Terminals

- 12–22 AWG (3.31–0.33 mm²).
- Stranded or solid core.
- Copper conductors only.

Universal outputs

The controller's universal outputs drive a 0–12 VDC signal.

Universal outputs can be used to provide a modulating signal to analog field devices and to energize relays with 12 VDC coils for binary applications. Reliable Controls universal outputs are provided with integral overload and short-circuit protection.

Note: Universal outputs are rated for loads that draw less than 75 mA. Loads that exceed 75 mA overload the thermal breaker internal to each output, resulting in intermittent cycling of the output.

Universal outputs must be connected to the OUT+ and OUT- (or GND) terminals while maintaining signal polarity. OUT+ on the controller must be connected to SIG+ on the field device, and OUT- (or GND) on the controller must be connected to GND (or COM) on the field device.

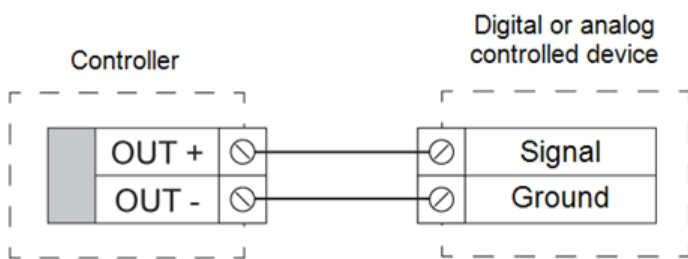

Figure 14: Typical universal output wiring for analog and binary

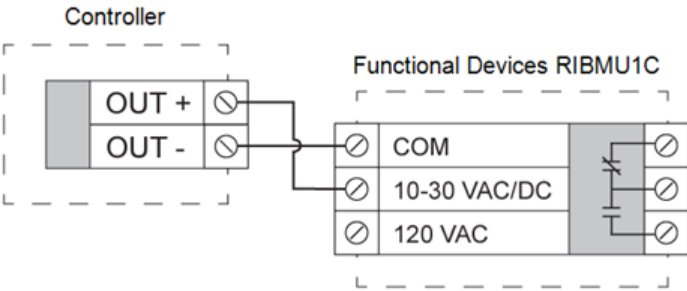

Figure 15: Universal output wiring for relay

Modulating output devices like valve and damper actuators require both a VDC signal reference for position and an external power supply to drive the motor.

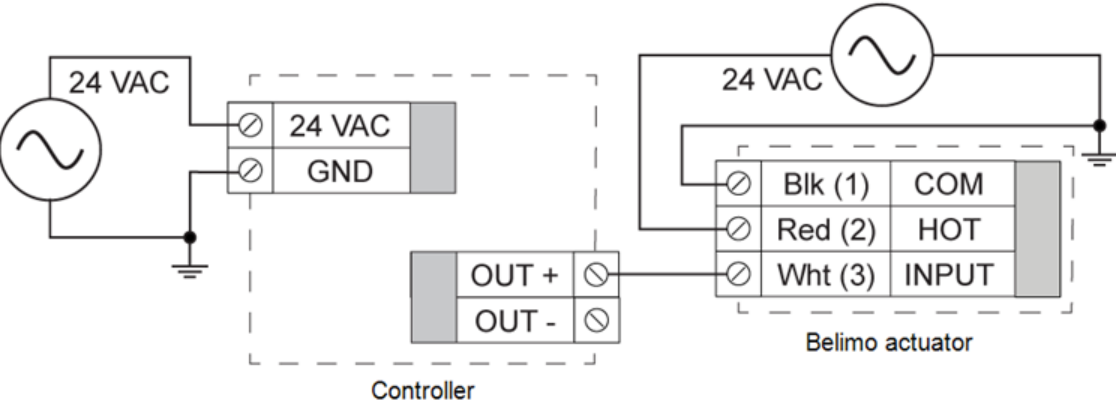

Figure 16: Universal output wiring with an external non-isolated power supply



Figure 17: Universal output wiring with an external isolated power supply

Output override potentiometer

Each output on your device has a potentiometer that controls the output's voltage when the Hand/Off/Auto (HOA) switch is set to Hand (H).

This is available only on controllers that have the optional HOA switch.

To decrease the output voltage, turn the potentiometer counterclockwise. To increase the output voltage, turn the potentiometer clockwise.

The output potentiometer does not affect the output when the HOA switch is set to Off (O) or Auto (A). Devices are shipped from the factory with the output potentiometers set at their full voltage.

Adjust the output voltage

Use the output's potentiometer to vary the output voltage potential when the output's Hand/Off/Auto (HOA) switch is set to Hand (H).

This is available only on controllers that have the optional HOA switch.

To adjust the output voltage potential with a voltmeter and a small screwdriver:

1. Open the controller cover to access the internal circuit board.
2. Set the HOA switch to H.
3. Set the voltmeter to measure DC voltage, and connect its leads to the output terminals.
4. While viewing the voltmeter reading, use the screwdriver to rotate the output potentiometer counterclockwise to decrease the voltage, or clockwise to increase the voltage, until the desired output voltage reading is displayed.
5. Disconnect the voltmeter.
6. Set the HOA switch to A.
7. Close the controller cover.

Hand/Off/Auto (HOA) switches

The optional HOA switch can override the controller's Auto setting to force the output to the Hand or Off setting.

For FLEX I/O, the HOA switch functions only if the FLEX I/O is configured as an output in RC-Studio.

In RC-Studio, the optional HOA switch setting is shown in the Switch column on the controller's Outputs worksheet. It displays Auto if there is no switch or the HOA switch is set to Auto.

Note: The output status LED always reflects the output state, even when the output is controlled by the HOA switch.

Hand (H)

The output is on, and the output voltage is set by the potentiometer.

Off (O)

The output is off.

Auto (A)

The output state is determined by the device's configuration and programs.

Note: Use proprietary BACnet property HOA_Switch (:1119) to read the switch position: Hand = 2, Off = 0, or Auto = 1.

Output LEDs

Outputs have LEDs that indicate the output voltage level.

The output LED brightness increases with the voltage potential between the output and ground or common. If the voltage is zero, the LED is off. At maximum potential, the LED is at its brightest. The LED brightness varies between those two states.

Peripheral power supply

Some devices may have a peripheral power supply.

The peripheral power supply, labeled Power Out, provides a low-voltage DC source to power compatible peripheral input transmitters and transducers.

Peripheral Power

- Onboard variable 15–24 VDC power supply provides up to 200 mA of DC power to peripheral devices. If powered with 24 VDC, the maximum voltage output is 22 VDC.

Wiring Terminals

- 12–22 AWG (3.31 mm² to 0.33 mm²).
- Stranded or solid core.
- Copper conductors only.

The Power Out GND terminal is internally connected to all ground terminals.

Before you wire the peripheral power supply, make sure the peripheral devices are compatible with the power supply specifications.

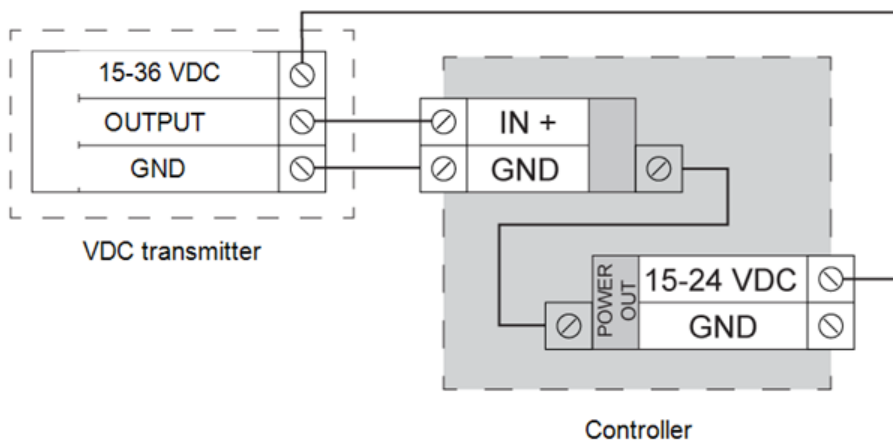

Figure 18: Peripheral DC power supply wiring to a VDC transmitter

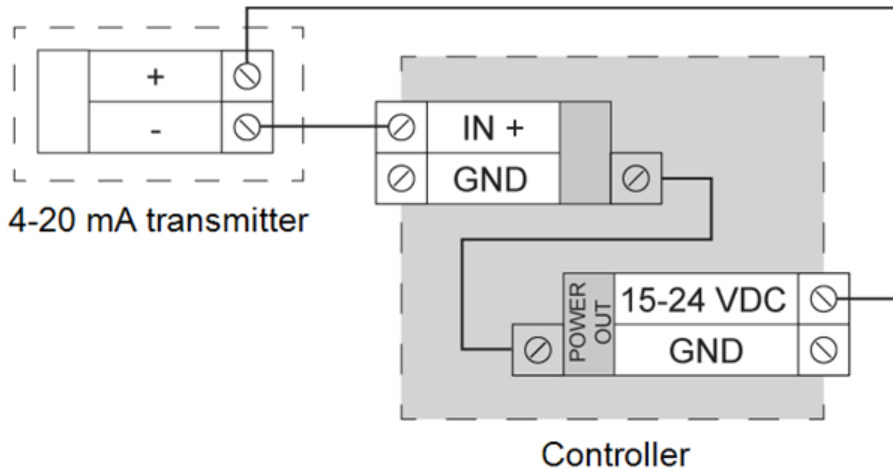

Figure 19: Peripheral DC power supply wiring to a 4-20mA transmitter

Peripheral power supply fuse

The onboard fuse limits the peripheral power supply current to 0.2 A, regardless of the output voltage. A replacement fuse, FU-250MA, is available in eBusiness in the Reliable Controls Support Center.

Peripheral power supply potentiometer

Use the peripheral power supply potentiometer to adjust the peripheral power supply voltage.

Adjust the peripheral power supply voltage

Use a voltmeter and a small screwdriver to adjust the DC voltage on the Power Out terminals.

1. Remove the detachable plastic door to access the internal circuit board.
2. Set the voltmeter to measure DC voltage, and connect its leads to the Power Out terminals.
3. While viewing the voltmeter reading, use the screwdriver to rotate the Power Out potentiometer dial counterclockwise to decrease the voltage, or clockwise to increase the voltage, until the desired output voltage reading is displayed.
4. Disconnect the voltmeter.
5. Reattach the plastic door.

Inputs and outputs label

Record the input and output connections on the label on the device's removable door.

Your device has a removable door with a label attached to one side where you can document device information and the input and output object names as they are defined in RC-Studio using standard object naming conventions.

The removable door is reversible and can be mounted with the label facing in or out.

Printable door labels are available in eBusiness and are listed on the controller's submittal sheet.

Download Microsoft Word templates for printing the labels at <https://www.reliablecontrols.com/support/engineer/templates.php>

Configuration

Configuration describes how to connect to the controller for the first time.

Once you establish the initial connection, you can configure network communications to take full advantage of the controller's networking capabilities and connect with Reliable Controls software products to configure, view, and manage your controller.

RC-Toolkit and your controller

Use RC-Toolkit to configure your controller's communications features and to upgrade controller firmware.

Upgrade RC-Toolkit to the latest release to support new features, improvements, and fixes.

RC-Toolkit has several tools for basic controller setup and troubleshooting:

- **MSet:** Use to set your controller's network and communication parameters.
- **OS Send:** Use to update your controller's firmware.
- **Network Diagnostics:** Use to view diagnostics for your controller to troubleshoot network issues.

RC-Toolkit includes the Panel File Utility, a separate program used to read and edit Panel Files and to rapidly duplicate and modify Panel Files to load to your controller.

Default MS/TP settings

The controller ships with the following default EIA-485 MS/TP settings:

- **BACnet device ID:** Not set.
- **EIA-485 baud rate:** Auto-detect.
- **End-of-Line switch:** Off.

Default PC/Modem settings

Your controller has factory default PC/Modem communication settings. It reverts to these settings when factory reset.

Note: Modems connected to the controller must be purchased from Reliable Controls.

Your controller's default PC/Modem communications settings are as follows:

Baud rate: 38.4 kB

Default user access settings

The factory-default user access settings used to log on to the system are stored in the host controller:

- **User:** longview
- **Password:** Empty, no entry



For BACnet network security best practices, refer to the *Reliable Controls Hardening Guide*, available under the Engineer tab in the Reliable Controls Support Center.

Connect using Direct Connect (PC/Modem)

Refer to the "PC/Modem Direct Connect or modem connections" topic for details on how to connect the controller's PC/Modem port to the computer or external modem.



Note: Open Microsoft Windows Device Manager > Ports (COM & LPT) to identify the serial communications port number to use in the RC-Toolkit Direct Connection settings.

To direct connect using EIA-232 serial communications:

1. Run RC-Toolkit.
2. In the RC-Toolkit menu, click **Options > Communications Preferences**.
3. In the Communication Preferences dialog box, confirm or configure the Direct settings. Click **Help**  for more information.
4. Click **Direct Connect** . The **Direct Connect** dialog box displays.
5. Depending on the controller type, select BACnet or Reliable (Reliable Controls Protocol) to connect.

Note: The baud rate specified on RC-Toolkit must match the baud rate on the controller PC/Modem port. Try setting RC-Toolkit to a different baud rate if the Direct Connect fails.

To remote connect using a modem:

1. Run RC-Toolkit.
2. In the RC-Toolkit menu, click **Options > Communications Preferences**.
3. In the Communication Preferences dialog box, confirm or configure the modem settings. Click  Help for more information.
4. Select a system configured for a modem connection and click **Connect** .
5. In the **Logon** dialog box, enter a user name and password for the system.

Note: Refer to the MSet topic for your controller in the RC-Toolkit online help for configuration details.

Connect to the controller's RJ11 SMART-Net port using an X-Port-2 Converter

Use the X-Port-2 Converter to connect a workstation running Reliable Controls software to the RJ11 SMART-Net port on a Reliable Controls system controller.

If your controller is in auto-baud detect mode, it must have a configured device ID to communicate with the X-Port-2 Converter as a standalone controller. Otherwise, connect your controller to a host controller's MS/TP port to define the baud rate and enable X-Port-2 Converter communication.

MACH-Pro(Web)Com/Sys and MACH-Pro1/MACH-Pro2 controllers must have Enable X-Port Access selected in the RC-Toolkit MSet tool to make a functioning X-Port-2 Converter connection.

You can Direct Connect a workstation to a controller using custom cables that connect the X-Port-2 Converter to the controller's SMART-Net port, then connect the X-Port-2 Converter to your workstation. Make sure you follow the connection sequence described in the following procedure.

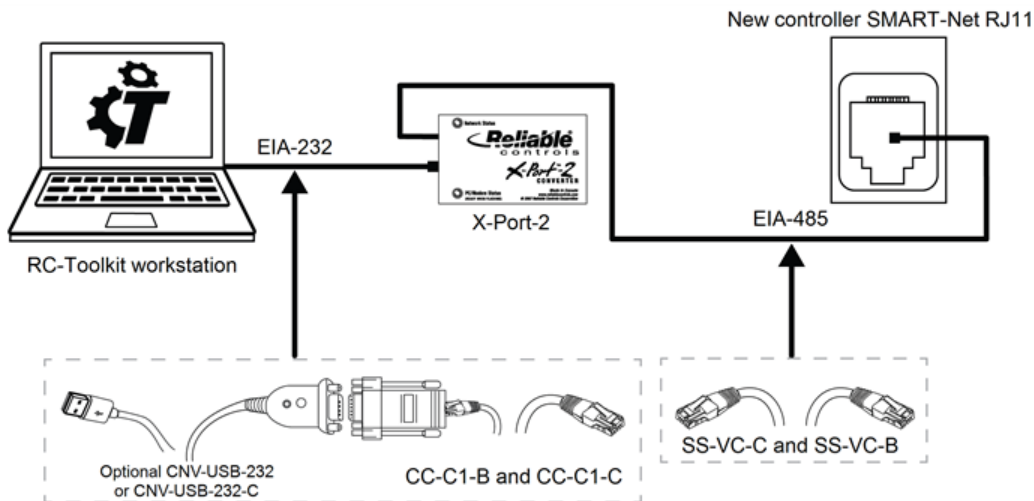

Figure 20: Controller connection to the SMART-Net port using an X-Port-2 Converter

To connect to your controller using an X-Port-2 Converter and custom cables:



1. Connect the SS-VC-C cable to the X-Port-2 Converter SMART-Net port and the RJ11 Smart-Net port on the controller.
2. Watch the PC/Modem LED on the X-Port-2 Converter. Do not proceed until the PC/Modem LED flashes once per second to indicate the connection is established.
3. Connect the X-Port-2 Converter PC/Modem port to your workstation using a Direct Connect cable (CC-C1-B base and CC-C1-C cable with CNV-USB-232 or or CNV-USB-232-C if required).
4. Open the Microsoft Windows Device Manager on your workstation to identify the communications port your workstation has assigned to the Direct Connect cable.
5. On the workstation, run the Reliable Controls software. Verify the BACnet Direct Connect (EIA-232) communications port corresponds to the Direct Connect communications port on your workstation.
6. Connect to the controller using BACnet Direct Connect, and configure your controller using Reliable Controls software.

Configure communications using the RC-Toolkit MSet tool

Use the RC-Toolkit MSet tool to configure the communications options on your controller.



The workstation running RC-Toolkit must have a communications connection to the controller.

To configure your controller using the MSet tool:

1. Run RC-Toolkit and connect to a system.
2. Click MSet  and select your controller in the System Tree. The MSet configuration interface displays.
3. Select and configure your controller's communication options.
4. Click **Send**  to send the updated parameters to your controller.

Enable X-Port-2 Converter access over SMART-Net

To enable X-Port-2 Converter access using the RC-Toolkit MSet tool:

1. Run RC-Toolkit and connect to a system.
2. Click MSet  and select the host controller in the System Tree. The MSet configuration interface displays.
3. In the SMART-Net area, select **Enable X-Port Access**.
4. Click **Send**  to save the changes to the controller.

The X-Port-2 Converter creates a direct communications connection from the SMART-Net port on your controller to a workstation running Reliable Controls software that can be used to configure your controller or view and edit controller and network information.

If your SMART-Net network contains SMART devices that have six-pin RJ11 connectors and you have chosen to extend MS/TP access by wiring up a 6 conductor SMART-Net network, you can connect the X-Port-2 converter to the SMART device to access your controller.

It is not recommended that you extend the MS/TP (EIA-485) network on the SMART-Net bus as it can create network issues related to excessive noise.

MACH-Pro1/MACH-Pro2 MSet configuration

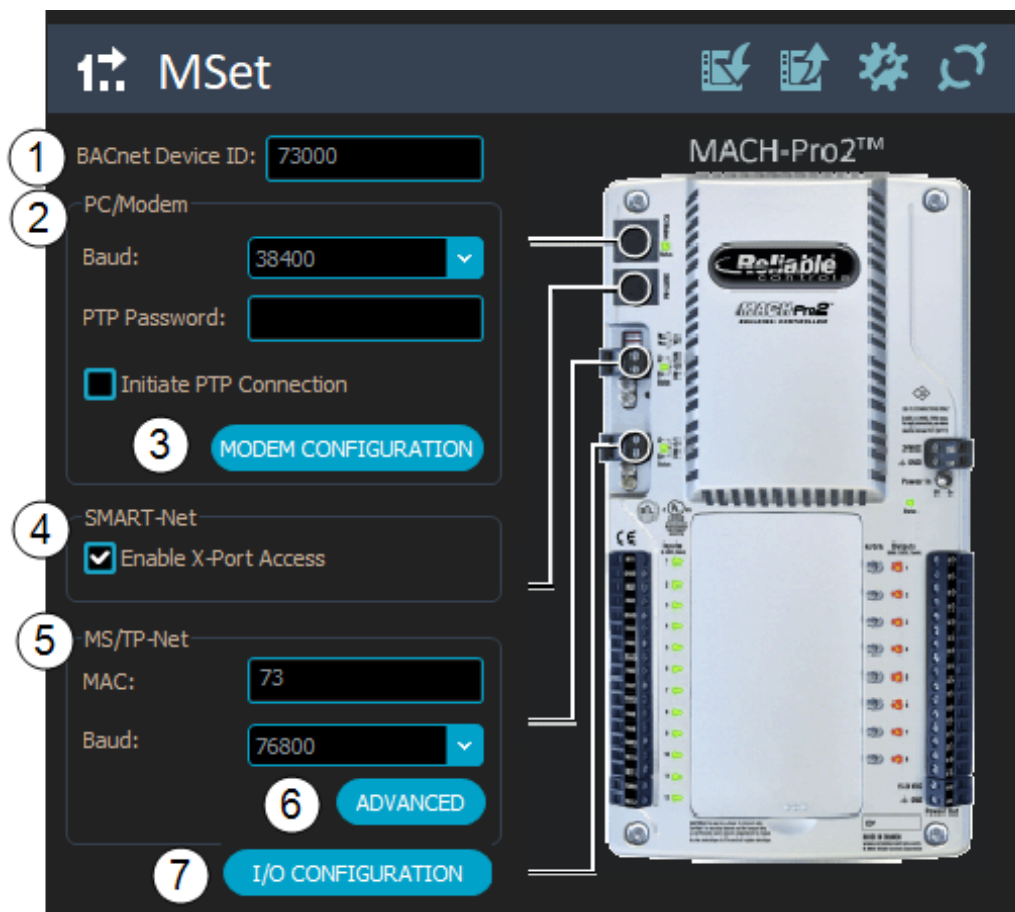

Actions

Print

Prints the current MSet settings to a document or printer.

Backup

Creates a backup file containing a backup of all properties configurable using the MSet tool. The backup file is stored as an .mset file at the following location:

C:\ProgramData\Reliable Controls\RC-Toolkit 3\MSet Backup

In addition to the MSet parameters, the Backup functionality also includes IO/Net configuration data.

Restore

Restores the .mset backup file.

Restoring a .mset file will not immediately send the configuration to the controller. After you load the file, the MSet tool displays the configuration properties from the backup file. You can change these properties before sending them to the controller. Click Send  to restore the data to the controller.

Restore Factory Defaults

Updates controller configuration using a set of default values consistent with a factory restored controller. This action will affect the same data as the backup/restore operation.

Set Master Password

The password that must be entered when connecting to the system.

① BACnet Device ID

BACnet Device ID

The BACnet Device ID must be a unique number on the BACnet internetwork, limited to between 1 and 4,194,302.

Note: Do not use device ID 0. Using zero can cause issues with older BACnet software and zero is not supported by RC-Studio.

② PC/Modem

Baud

Baud is the rate of data transmission on a network. In accordance with the BACnet standard, the controller can communicate at 9600,19200, 38400, 57600 and 115200 baud. 38400 baud is the default.

PTP Password

The PTP Password field may be required by a BACnet PTP device connected to the port.

Initiate PTP Connection

Enable to create a persistent connection to a 3rd party device that is limited to a BACnet PTP connection. Leave disabled when using BACnet Direct Access.

3 Modem Configuration Button

Modem Configuration

Modem Initialization String:

Dial-Out Setup

Data Bits	Parity Bits	Stop Bits
<input type="radio"/> 7-bit	<input checked="" type="radio"/> None	<input checked="" type="radio"/> One
<input checked="" type="radio"/> 8-bit	<input type="radio"/> Odd	<input type="radio"/> Two
	<input type="radio"/> Even	

Modem Initialization String

The Initialization String field value is utilized by the controller to initialize an external modem connected to this port.

Data Bits

The number of data bits in each character. The default is 8-bit.

Parity Bits

The parity bit in each character can be set to None, Odd, or Even. The default is None

Stop Bits

Stop bits sent at the end of every character allow the receiving signal hardware to detect the end of a character and to resynchronise with the character stream. Default is one.

4 SMART-Net

Enable X-Port Access

Enabling the Enable X-Port Access field creates an internal physical connection between MS/TP Net and two poles of the SMART-Net port. If enabled, operators can connect their RC-Studio workstation to the SMART-Net port, or to any SMART-Sensor wired to the SMART-Net port, using the X-Port-2 converter (providing a network connection exists at the MS/TP level). If disabled, MS/TP-Net is isolated from the SMART-Net bus, preventing X-Port-2 communications and eliminating a possible source of EIA-485 network noise in the system.

5 MS/TP-Net

MAC

The MS/TP address, also referred to as the MAC #, of the device on the network. The MAC must be unique for each device on the MS/TP network and range from 1-126.

Baud

Baud options are 9600, 19200, 38400, 76800 and Auto-baud (default).

6 Advanced Button

BACnet Network#

The BACnet Network # field value is automatically generated and should only be modified if that number is already used in the network. Manually entered values must be between 1-65,534.

7 I/O Configuration Button (MACH-Pro2 only)

Click the **I/O Configuration** button to display the I/O Configuration dialog box. This option is only available on MACH-Pro2 controllers.

Module:	Type:	Inputs	Outputs
1:	MPP-IO	1...12	1...8
2:			
3:			
4:			
5:			
6:			
7:			
8:			

Number of Modules

Select the number of expansion modules that will be connected to the MACH-Pro2 controller.

Type

Select the appropriate expansion module type for each module address (MPP-IO, MPP-O, or MPP-I). MSet will not allow selection of more than 3 modules.

Inputs

Shows the number of available inputs for the expansion module selected in the Type column.

Outputs

Shows the number of available outputs for the expansion module selected in the Type column.

Baud rate configuration

The controller is factory-set with the baud rate set to auto-detect so you can easily add it to an existing MS/TP network.

When you configure your controller over an MS/TP network, part of that configuration should include setting a fixed baud rate. Use the MSet tool in RC-Toolkit to set the baud rate for all devices on the network. Some devices allow you to set the baud rate on each device individually.

Note: You cannot set the baud rate on an individual MS/TP-only controller; instead you must use the MSet tool in RC-Toolkit to set the baud rate for all devices on the MS/TP-Net network.

How auto-detect works

When the controller powers up in auto-detect mode, it listens on the default baud rate of 76800 for valid MS/TP communication.

- If the controller detects a valid MS/TP frame, which indicates an active, functioning MS/TP network, it starts normal MS/TP communications at that baud rate.
- If the controller detects invalid network activity, it waits for a period of time, then goes back through the auto-detect process of listening on the different baud rates for valid MS/TP network communications.
- If the controller does not detect valid MS/TP communications, the controller goes to the next lowest baud rate to listen for valid MS/TP communications.
 - If the controller cycles through all the baud rates and does not detect any valid MS/TP communication, it returns to the default baud rate and listens to determine its next action.
 - If the controller does not detect any network activity for a set period of time, it assumes it is the only manager on the network. The controller generates its own token and communicates over MS/TP at the default baud rate.

Why set a fixed baud rate?

If you have a simple MS/TP network, with short cable runs and devices with similar power-up durations that operate at the default baud rate of 76800, you may not have any issues with leaving your device's baud rate in auto-detect.

If you have a complex MS/TP network, with subnetworks, long cable runs, and devices with different power-up durations from different manufacturers that do not operate at the default baud rate of 76800, setting a fixed baud rate helps your MS/TP network recover from a power cycle or reset.

Auto-detect can cause MS/TP network issues if the following conditions are present:

- If the device that defines the network's baud rate—the baud manager—has a long power-up duration, during the delay the other devices on the network define the network's baud rate and start communicating. If the baud rates are different, the baud manager can't communicate on the MS/TP network.
- If the network has long and noisy cable runs, devices in auto-baud always detect network errors. This can put auto-baud devices in a condition where they continuously cycle through the different baud rates, but because they do not find any valid MS/TP communications, they cannot detect the correct network baud rate.

For more information, refer to *Application Notice 14, EIA-485 Wiring Types*, and *Application Notice 20, Troubleshooting EIA-485 Networking Problems*, available on the [Reliable Controls Support Center](#).

For these reasons, Reliable Controls recommends setting a specific baud rate on all MS/TP networked devices.

Note: Use RC-Toolkit to send a network configuration message that sets the baud rate for all devices on the MS/TP network.

Identify and troubleshoot auto-detect baud rate issues

Observe the controller's status LED. If it is flickering green, it is communicating normally on the MS/TP network. If it is green and blinking on/off, there is a network communication issue.

Connect an MSet Tool to the controller to view the current baud rate.

Connect to your network using RC-Toolkit, select an MS/TP device, and select the Network Diagnostics tool. In the Network Diagnostics tool, click **Advanced**, and select **MS/TP** to view information about the MS/TP network. The following list of values can help you identify issues related to auto-detect baud rate settings:

- **Link speed:** The baud rate, which should be the same value for all devices on the MS/TP network.
- **Baud changes :** The number of times the baud rate has changed. If this value is increasing, it could indicate an auto-detect race condition.
- **Total UART errors:** The total number of UART errors. If this value is increasing, it could indicate data at other baud rates on the network.

Refer to RC-Toolkit online help for detailed information about the Network Diagnostics tool.

Default MS/TP settings

The controller ships with the following default EIA-485 MS/TP settings:

- **BACnet device ID:** Not set.
- **EIA-485 baud rate:** Auto-detect.
- **End-of-Line switch:** Off.

Reset button operation

Use the reset button to clear the controller's Panel File or the controller's Panel File and MSet network configuration.

Note: Only use the reset button when absolutely necessary. Read and understand the following material before you use it.

Before you reset your controller, back up your controller's Panel File using RC-Studio. When you reset the controller, all data is cleared on the controller, including configuration and programming.

Reset a controller if you are installing a previously used device in a new location and want to remove all information associated with the previous installation. Resets do not affect the controller's firmware.

The reset button is functional only if you press it while the controller is powered down and keep pressing it while the controller powers up. Pressing the reset button has two possible results, depending on how long you hold it:

- **Database** : Press and hold the reset button, power the controller, and release after two flashes of the status LED, approximately 2 seconds. This operation clears the Panel File from the controller but does not affect network settings such as device ID. The controller's functions are restored if you load an appropriate Panel File.
- **MSet** : Press and hold the reset button, power the controller, and release after 10 flashes of the status LED, approximately 10 seconds. This operation clears the database and restores the controller to its factory defaults, including network configuration settings such as addressing. After an MSet reset, the controller's network settings are cleared, and you must configure it with an address and other parameters to restore communications. The controller's functions are restored when you load an appropriate Panel File.

Controller database

This controller is a BACnet-only device that can read and write BACnet object information from other Reliable Controls controllers connected to the network, up to a fixed limit.

The SHARE or SHARE-NET function must be written into a Control-BASIC program running on the controller so it can share its information with a SMART-Space controller.

RC-Studio and your controller

Use RC-Studio to configure the functions available on your controller. Upgrade to the latest software release for new features, improvements, and fixes.

Use the worksheets in RC-Studio to configure your controller's input and output characteristics and any connected SMART-Net devices. You can also define the controller's objects, such as values, trend logs, loops, and calendars, in RC-Studio worksheets. Create System Groups and write programs in the software to provide a graphical interface to your Reliable Controls system.

The RC-Studio System Tree includes a Network Status worksheet for each network that displays controller information, including the firmware version and available memory.

For more information, refer to the RC-Studio online help. eLearning courses are available in the Reliable Controls Learning Center.

Point Status BACnet property

Use the Point Status BACnet property to read an object's status as a number value for Control-BASIC programming. The Reliable Controls proprietary BACnet property Point_Status (:1338) returns an enumerated value based on the object and the object's state.

Reliable Controls proprietary BACnet properties are available in eForum on the [Reliable Controls Support Center](#).

This property is included on the following version 8 hardware and firmware controllers:

- MACH-ProAir, MACH-ProZone, MACH-ProLight
- MACH-Pro1, MACH-Pro2
- MACH-ProView
- MACH-Pro(Web)Com/Sys
- RC-FLEX controllers

The following table lists the objects and the enumerated values that describe the object state:

Object type	Enumerated values	Notes
Calendar, programs, inputs, loops, schedules	0: Auto 1: Timed override 2: Manual	Write 0 to this property to return the object to automatic mode.
Outputs, values	0: Auto	Write 0 to this property to return the object to

Object type	Enumerated values	Notes
(all types)	1: Timed override 2: Manual 3: Priority override (priority other than 8 or 10) 4: Out of service (outputs only) 5: Overridden HOA off 6: Overridden HOA hand	automatic mode, clear out of service, and relinquish all priorities except: <ul style="list-style-type: none"> • 1: Life safety • 6: Minimum off/on time • 10: Auto

Net Ins and Net Outs BACnet properties

Use these BACnet properties to monitor and control some aspects of Net Ins and Net Outs.

- **Object Type:** 8 (Device)
- **Instance:** Device ID

These properties are available in firmware version 8.31 or later.

COV_Notification_Mode (:1360)

This property is not available for the MACH-Pro1 and MACH-Pro2.

0: Default Unique Net Outs are created for every local BACnet/IP device that requests that point.

1: Net Outs are consolidated into a single Net Out for local BACnet/IP devices that request that point. This setting is recommended for large RC-FLEX networks.

Net_Ins_Error_Count (:1362)

Returns the number of Net Ins in error. Type: Unsigned integer. Refer to the Control-BASIC example.

Net_Outs_Error_Count (:1363)

Returns the number of Net Outs in error. Type: Unsigned integer. Refer to the Control-BASIC example.

Control-BASIC example

The following Control-BASIC example uses the Net Ins property to generate a delayed alarm when problems occur. Specify a 2-minute (120-second) delay to prevent nuisance alarms that may occur in situations such as system recovery after a power cycle.

```
10 DALARM MYCONTROLLER123:1362 > 0 , 120 , "Error retrieving values on the network"
```

Object instance BACnet property

The Object_Instance (:1395) BACnet property returns the instance number of an object. You can use this property to determine the device number.

This BACnet property is available in firmware version 8.31.5 or later.

This property is available for reference in System Groups, Control-BASIC, and anywhere else that supports BACnet properties.

Note: The SMART-Sensor EPD is limited to displaying values between 1 and 65535.

The following example code stores the device number of the local device in variable A:

```
10 A = DEV4194303:1395
```

Supported Control-BASIC

Your controller supports a subset of Control-BASIC statements and functions.

Note: If your controller's runtime interpreter comes across a statement or function it does not support, the program exits at that line and sets the Exit status for that program to Yes.

Supported Control-BASIC statements

The following table lists the Control-BASIC statements supported by your controller:

Alarm/Print	Execution control	Point command	Miscellaneous
ALARM	CALL	CLEAR	REM
ALARM-TYPE	DECLARE	CLOSE	
APDIAL	END	ENABLE / DISABLE	
DALARM	FOR	IDLE	
HANGUP	IF / IF+ / IF-	LET	
ON-ALARM	GOSUB	OPEN	
ON-ERROR	GOTO	RELINQUISH	
	NEXT	SET-PRIORITY	
	ON	START	
	PHONE	STOP	
	RETURN	WRITE	
	SHARE		
	SHARE-NET		
	WAIT		

Supported Control-BASIC functions

The following table lists the supported Control-BASIC functions:

Math		System access	Time
ABS	LN	CONPROP	DOM
ARCCOS	LN-1	CONRATE	DOW
ARCSIN	LSEL	CONRESET	DOY
ARCTAN	MAX	POWER-LOSS	INTERVAL
AVG	MAX-ITEM	RAMP	TIME
BIT-SET	MIN	SCANS	TIME-OFF
BIT-TEST	MIN-ITEM	SCHED	TIME-ON
COS	SELECT	SENSOR-OFF	
ENTHALPY	SIN	SENSOR-ON	
FLOAT	SLIDE	TBL	
HSEL	SQR		
INT	SWITCH		
LIMIT	TAN		

Specifications

Your controller has detailed technical specifications.

For the most up-to-date specifications, refer to the Reliable Controls Dealer Support Center for the catalog and submittal documents for your controller.

MACH-Pro2 technical specifications

Processor

- 100 MHz high-performance 32-bit embedded microcontroller.

Memory

- 8 MB operating RAM.
- 1 MB nonvolatile RAM for trends and dynamic values.
- 4 MB Flash EEPROM operating system, database, and controller configuration.

Wiring Terminals

- 12–22 AWG (3.31–0.33 mm²).
- Stranded or solid core.
- Copper conductors only.
- Wiring to be rated for at least 75 °C (167 °F).
- The maximum tested SMART-Net cable length from the host controller to the last SMART-Net device on the SMART-Net bus is 45 m (147 ft). With an externally powered SMART-Net Expansion Board or SMART-Sensor Expansion Board located at the network midpoint, the maximum tested SMART-Net cable length from the host controller to the last SMART-Net device on the SMART-Net bus is 75 m (246 ft).
- SMART-Net 6-pin RJ11 connector — three pair UTP solid core telecommunications data cable:
 - 0.13 — 0.21 mm² (26 — 24 AWG)
 - Category 3 or Category 5
- EIA-485 wiring — 0.32 mm² (22 AWG) Triad shielded twisted low capacitance certified communications cable.
 - Characteristic impedance — 108 Ω.
 - Capacitance < 98 pF.m (30 pF.ft).
 - Maximum segment length — 1220 m (4000 ft)

Supply Voltages

- 24 VAC ±10%, 75 VA maximum, 50/60 Hz.
- 24 VDC ±10% 26 W maximum.

Communication Options

- Two EIA-485 ports that support a baud rate up to 76.8 kbps. Auto baud detection.
- One EIA-232 port that supports a baud rate up to 115.2 kbps. PC or modem.
- One SMART-Net port that supports up to 16 devices on a SMART-Net network.

Universal Inputs

- 12 universal inputs.
- 12-bit A/D converter.
- Analog: 0–10 VDC, 4–20 mA, thermistor.
- Binary: Dry contact.
- Impedance:
 - 1 M Ω for 0–10 VDC range.
 - 250 Ω for 4–20 mA range.
 - 20 k Ω pull-up for thermistor/dry contact range.
- Pulse counting up to 150 Hz. Supports flow meters.
- 24 VAC overvoltage protection.

Universal Outputs

- 12-bit D/A converter.
- Analog: 0–12 VDC.
- Binary: Software-configurable between 0–12 VDC.
- Manual on provides adjustable 0–12 VDC on controller with HOA option.
- LED indicator glows proportionally.
- Maximum 75 mA each.
- 24 VAC overvoltage and short protection.

Expansion Modules

- Add up to three MACH-ProPoint expansion modules.

Peripheral Power

- Onboard variable 15–24 VDC power supply provides up to 200 mA of DC power to peripheral devices. If powered by VDC, the maximum voltage output is 22 VDC.

Real-Time Clock

- ± 1 second per day.

Memory/RTC Backup

- 72-hour backup.
- 10 years for database.

Dimensions

- 25.4 cm L x 13.7 cm W x 3.9 cm H
(10" L x 5 3/8" W x 1 1/2" H).

Mounting

- #8 clearance holes on 23 cm L x 11 cm W
(9 1/16" L x 4 5/16" W).
- Screw depth 25 mm (1").

Weight

- 0.60 kg (1.3 lb).

Ambient Limits

- Operating: -20°C to 55°C (-4°F to 131°F).
- Shipping: -40°C to 60°C (-40°F to 140°F).
- Humidity: 10%–90% RH noncondensing.

Certifications

- BTL Listed (B-BC).
- UL 916 Listed.
- FCC CFR 47 Part 15 Class B.
- CE.
- WEEE.

I/O-Net communications for MACH-ProPoint

The controller has an EIA-485 port that supports the I/O-Net protocol, which allows you to add inputs and outputs to the controller by connecting one or more MACH-ProPoint expansion modules and configuring the modules using the RC-Toolkit MSet tool.

The maximum number of MACH-ProPoint modules a host controller can support depends on the controller model:

Host controller	Maximum MACH-ProPoint modules supported
MACH-ProComand MACH-ProWebCom	8
MACH-ProSys and MACH-ProWebSys	7
MACH-Pro2	3
MACH-ProViewrouter models only (-R)	1

The I/O-Net network self-terminates with each MACH-ProPoint expansion module and does not need End-of-Line (EOL) switches or jumpers.

MACH-ProPoint expansion modules can be located remotely from their host but are not intended to be a building-wide network. The modules communicate to the controller 10 times per second, regardless of the controller's scanning rate. Inputs cannot be read more than 10 times per second, but MACH-ProPoint expansion modules incorporate onboard pulse accumulation so that input information is not limited by the communication rate.

MACH-ProPoint expansion module wiring

Use a straight-line topology to connect MACH-ProPoint modules to the host controller's EIA-485 port that is configured for I/O-Net communications.

Maximum I/O-Net segment length: 152 m (500 ft).

The MACH-ProPoint expansion module's I/O-Net terminal block has two terminals: A(-) and B(+). The I/O-Net connection is non-isolated and internally references the device's power ground. The MACH-ProPoint I/O-Net connection is protected by onboard, automatically resetting polyfuses or network protection bulbs.

The I/O-Net cable shield must be continuous and connected to ground at only one point.

To connect multiple MACH-ProPoint expansion modules, use the EIA-485 connector to wire terminal A (-) to A(-), and B(+) to B(+). Connect the bare shield wires at each junction to help suppress noise along the cable length.

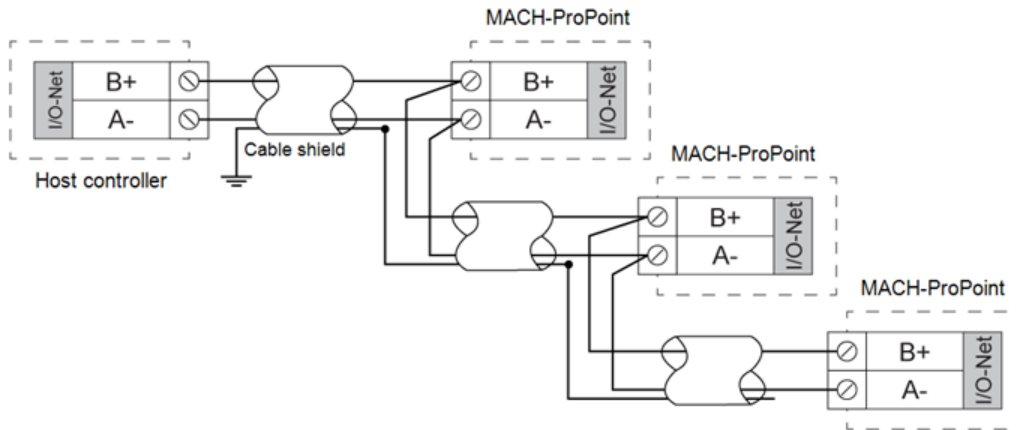

Figure 21: I/O-Net wiring

Note: The maximum number of MACH-ProPoint modules a host controller can support depends on the controller model. For the most complete, up-to-date information, click your product on the [Products](#) page to access the submittal sheet.

MACH-ProPoint I/O-Net address

Set the MACH-ProPoint I/O-Net address using the addressing DIP switches.

DIP switch address settings are listed on the MACH-ProPoint's protector-director, attached to the internal circuit board.

The MACH-ProPoint only reads its I/O-Net address when powering up. If the address is changed, you must power cycle the MACH-ProPoint to set the new I/O-Net address.

For I/O-Net networks hosted by MACH-ProSys, MACH-ProWebSys, MACH-ProView router model, and MACH-Pro2 controllers, the MACH-ProPoint I/O-Net addresses start at 2 because I/O-Net address 1 is used by the controller. For I/O-Net networks hosted by the MACH-ProCom and MACH-ProWebCom controller, the I/O-Net address starts at 1.

All MACH-ProPoint addresses must be sequential. An empty address space indicates the end of the network.

Refer to the controller's submittal sheet for information on the maximum number of MACH-ProPoint expansion modules you can add to the controller's I/O-Net network.

I/O-Net status LEDs and network protection

The I/O-Net port LED provides network status information. This topic applies to:

- The MACH-Pro2 I/O-Net port.
- The MACH-ProPoint I/O-Net port.

MACH-Pro2 I/O-Net status LED behavior

Continuous rapid flashing

Normal operation.

One flash/second

One or more MACH-ProPoint expansion modules are not communicating.

Off

No MACH-ProPoint expansion modules detected, either because there are no modules connected or there is a wiring error.

MACH-ProPoint I/O-Net status LED behavior

Rapid flash

Normal operation, communicating with the host controller.

On continuously, or on 2 seconds, off 2 seconds

Error. I/O-Net network has duplicate addresses.

Off

Not operational. Unpowered, or the host controller is not correctly configured, or the I/O-Net port is not correctly wired.

EIA-485 network protection

The device uses network protection bulbs to protect the EIA-485 port from issues such as ground reference difference or a miswired power connection.

The bulbs light up and remain lit until the issue is resolved.

Replacement network protection bulbs are available for order as Reliable Controls part number NA-BULB.

MACH-ProPoint host I/O-Net configuration

Use the RC-Toolkit MSet tool to configure the host controller's I/O-Net network of MACH-ProPoint expansion modules.

The number of supported MACH-ProPoint modules is based on the host controller and incorporated into the MSet tool when configuring the controller's I/O-Net network.

Add MACH-ProPoint expansion modules to the host controller

Use the RC-Toolkit MSet tool to configure the host controller's AUX-Net port to support an I/O-Net network of MACH-ProPoint expansion modules:

1. Start RC-Toolkit and connect to the system .
2. Select the MSet tool, then select the host controller to open its MSet configuration view.
3. In the AUX-Net area, click **Protocol** and select **I/O-Net**.

4. Click **I/O-Net Configuration** to open the I/O-Net Configuration dialog.
5. In the I/O-Net Configuration dialog, select the number of MACH-ProPoint expansion modules on the I/O-Net network to create blank module rows. If I/O-Net address 1 is used by the host controller, the row for module 1 contains the host controller I/O information.
6. Set the **Type** for each module based on the physical MACH-ProPoint expansion module located at that I/O-Net address.
7. Click **OK** to close the I/O-Net Configuration dialog.
8. Click **Send** to save the I/O-Net configuration to the host controller.

MACH-ProPoint host database configuration

The MACH-ProPoint expansion module's database configuration is stored on the I/O-Net host controller.

Use RC-Studio to configure the host controller.

MACH-ProPoint expansion modules in RC-Studio

MACH-ProPoint expansion module information is included in the RC-Studio Inputs and Outputs worksheets.

On the RC-Studio Inputs and Outputs worksheets, the first column for a MACH-ProPoint input or output includes information about the MACH-ProPoint module address and the input or output instance.

The following example shows how RC-Studio displays a connected MACH-ProPoint expansion module.

	Name	Value			Auto/Man	
1 (1-1)	Rm 101 lights	Off	***	Auto	▼	
2 (1-2)	Rm 102 lights	Off	***	Auto	▼	
3 (1-3)	MPWS-OUT3	Off	***	Auto	▼	
4 (1-4)	MPWS-OUT4	Off	***	Auto	▼	
5 (1-5)	MPWS-OUT5	Off	***	Auto	▼	
6 (1-6)	MPWS-OUT6	Off	***	Auto	▼	
7 (1-7)	MPWS-OUT7	Off	***	Auto	▼	
8 (1-8)	MPWS-OUT8	Off	***	Auto	▼	
9 (2-1)	First column shows connected MACH-ProPoint expansion module (MPP-IO) Address = 2 Output instance = 1 to 8	Off	***	Auto	▼	
10 (2-2)		Off	***	Auto	▼	
11 (2-3)		Off	***	Auto	▼	
12 (2-4)		Off	***	Auto	▼	
13 (2-5)		Off	***	Auto	▼	
14 (2-6)		Off	***	Auto	▼	
15 (2-7)		Off	***	Auto	▼	
16 (2-8)		Off	***	Auto	▼	
17						

An X appearing in the first column indicates that the host controller is unable to communicate with the MACH-ProPoint expansion module.

- Check the I/O-Net wiring connections, ensuring correct polarity.
- Check the MACH-ProPoint address DIP switch is set correctly and matches the I/O-Net setting in the RC-Toolkit MSet tool.
- Check the correct MACH-ProPoint type is selected in the I/O-Net Configuration dialog.
- If the address was changed, you must power-cycle the MACH-ProPoint module.

Identify connected MACH-ProPoint modules

Use the RC-Studio **Device** dialog to identify the type and firmware for connected MACH-ProPoint modules.

To identify the MACH-ProPoint modules connected to the controller:

1. Connect to the controller using RC-Studio.
2. In the System Tree, right-click the controller and select **Properties**.
The **Device** dialog displays.
3. View the information in the **General > Firmware**. Newer firmware displays the MACH-ProPoint type and firmware. Older firmware identify the connected MACH-ProPoint modules based on the following example:

8.24 | 01, 10 | 02-03 | 03-02 |

- 8.24: The controller's firmware version.
- 01, 10: MACH-ProPoint Input/Output (MPP-IO) or MACH-ProPoint Input/Output Universal (MPP-IO-U) module running firmware version 10.
- 02-03: MACH-ProPoint Input (MPP-I) module running firmware version 03.
- 03-02: MACH-ProPoint Output (MPP-O) module running firmware version 02.

I/O-Net lost connection behavior

If the I/O-Net connection is lost, the host controller retains the last known good values, and the MACH-ProPoint outputs are set to 0.