

# **MACH-ProZone™**

Advanced Unitary Controller

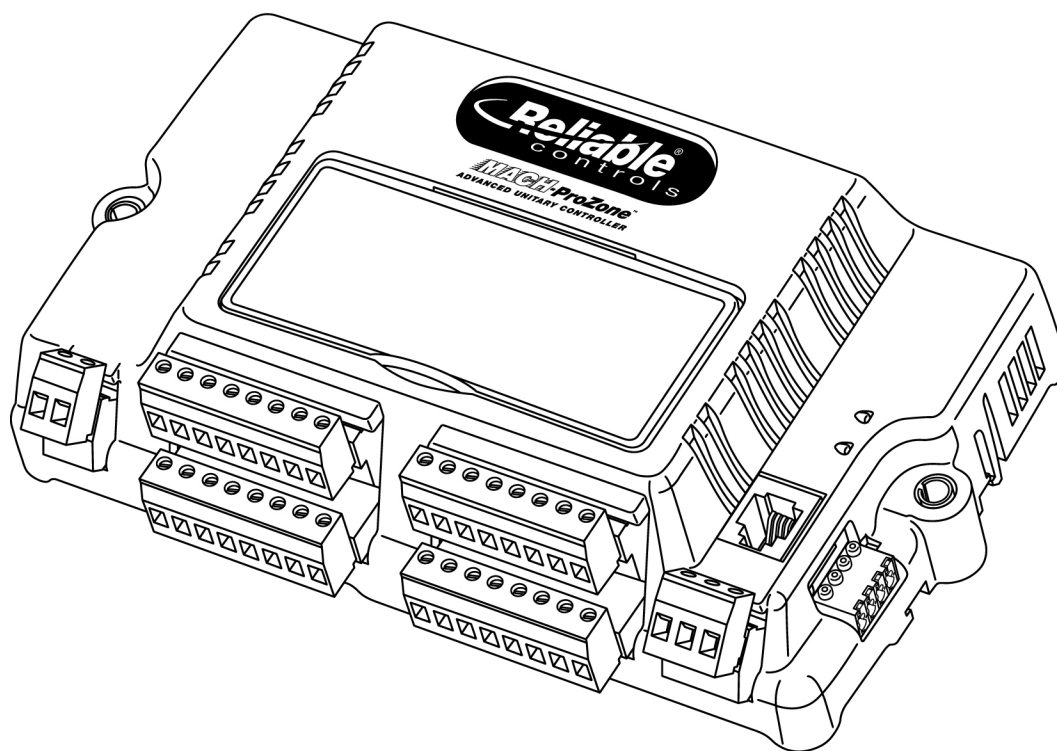

Better by design™

User Guide

**Reliable®**  
controls

© 2000-2025 Reliable Controls® Corporation. All rights reserved.

This manual is for information purposes only. The contents and products described are subject to change without notice. Reliable Controls Corporation makes no representation with respect to this manual. In no event shall Reliable Controls Corporation be liable for damages, direct or incidental, arising out of or related to the use of this manual. Parts of this document may not be reproduced or transmitted in any form or by any means, without the express written permission of Reliable Controls Corporation.

Reliable Controls® Corporation

120 Hallowell Road

Victoria, BC, V9A 7K2

Phone 1-250-475-2036

Toll-Free: 877-475-9301 (US & Canada Only)

Fax: 250-475-2096

Email: [info@reliablecontrols.com](mailto:info@reliablecontrols.com)

[reliablecontrols.com](http://reliablecontrols.com)

Reliable Controls, myControl, RC-Archive, RC-FLEXair, RC-FLEXone, RC-GrafXSet, RC-Hospitality, RC-LicenseManager, RC-Passport, RC-RemoteAccess, RC-Reporter, RC-Studio, RC-Toolkit, and RC-WebView are registered trademarks of Reliable Controls Corporation.

BACnet is a registered trademark of ASHRAE.

FlexTile, MACH1, MACH2, MACH-Air, MACH-CheckPoint, MACH-Global, MACH-Pro1, MACH-Pro2, MACH-ProAir, MACH-ProCom, MACH-ProLight, MACH-ProPoint, MACH-ProSys, MACH-ProView, MACH-ProWeb, MACH-ProWebCom, MACH-ProWebSys, MACH-ProZone, MACH-Sentry, MACH-Stat, MACH-System, MACH-Zone, SMART-Sensor, SMART-Net, SMART-Space, and SPACE-Sensor are trademarks of Reliable Controls Corporation.



# Contents

MACH-ProZone overview .....	5
Product features .....	5
Product models and accessories .....	7
Standard applications .....	8
MACH-ProZone topologies .....	8
MACH-ProZone with SMART-Net devices .....	10
MACH-ProZone hardware overview .....	12
Additional resources .....	12
MACH-ProZone installation and wiring .....	14
Installation considerations .....	14
MACH-ProZone power .....	14
Grounded power .....	14
MACH-ProZone SMART-Net .....	15
SMART-Net four-pin terminal .....	15
SMART-Net RJ11 .....	16
MACH-ProZone MS/TP network .....	17
EIA-485 wiring for grounded controllers .....	17
End-of-Line switch .....	18
End-of-Line (EOL) LED .....	18
Status LED and network protection .....	19
MACH-ProZone inputs .....	19
Inputs .....	20
MACH-ProZone outputs .....	21
Output jumpers .....	22
Set the output jumpers .....	22
Solid-state relay outputs without R~ terminal .....	22
Universal outputs .....	23
Install the MACH-ProZone .....	23
Configuration .....	24
RC-Toolkit and your controller .....	24
Default user access settings .....	24
Default MS/TP settings .....	24
Initial MS/TP connection .....	24

Connect to an existing MS/TP network .....	25
Direct connect to controller using X-Port-2 .....	25
Set up MS/TP communications using RC-Toolkit .....	27
Non-router MS/TP controller MSet .....	27
Set up MS/TP communications using the SMART-Sensor MSet Tool .....	29
Baud rate configuration .....	30
MACH-ProZone reset button .....	32
Reset button operation .....	32
<b>Controller database .....</b>	<b>33</b>
RC-Studio and your controller .....	33
Point Status BACnet property .....	33
Database storage and configuration .....	34
Supported Control-BASIC .....	35
<b>Specifications .....</b>	<b>37</b>

# MACH-ProZone overview

Small, durable, and packed with flexibility, the Reliable Controls MACH-ProZone™ is a fully programmable BACnet Building Controller (B-BC) with highly scalable inputs and outputs in a compact footprint.

The MACH-ProZone is ideal for a wide range of applications that include small to mid-sized roof top and heat pump applications, and small mechanical room applications. The controller features up to 8 universal inputs and up to 8 universal outputs with jumper-selectable relay configuration. The MACH-ProZone ships standard with removable terminal blocks and support for 8 SMART devices.

## Product features

For the most complete, up-to-date information, click your product on the [Products](#) page to access the submittal sheet.

### Dynamic Database

- Create up to 160 objects of any supported type in any model of controller.
- Maximum of 128 objects of a single type.
- Refer to the Typical Object Configuration table below for memory usage.

### Protocol

- BACnet MS/TP.

### Programs

- 16,000 bytes of programmable control strategy in a readable, BASIC-like language.
- 3,200 bytes per program.

### Inputs

- Universal ranges.
- Soft selectable 0–10 VDC, 4–20 mA, thermistor/dry contact.

### Outputs

- Universal ranges.
- Use jumper to select as 0–12 VDC or solid-state relay driver.

### Values

- Select standard and custom ranges as well as fixed or program-driven values.

### Loops

- Standard P, PI, or PID controllers for closed loop control.

### Single-point Trend Logs

- Record values at user-defined intervals or based on change of value.
- Dynamic; user assigned.

### **Multipoint Trend Logs**

- Store up to eight objects in each trend log.
- Record values at user-defined intervals.
- Dynamic; user assigned.

### **Runtime Report**

- Total on time and record the on/off times of every binary object.
- Automatically generated.

### **System Groups**

- Group related objects on one display.
- 80 unique objects per group.

### **Schedules**

- Up to 7 on/off cycles for each weekday or exception.

### **Calendars**

- Designate days of the year as holidays.

### **Arrays**

- Up to 128 elements in a one-dimensional array.

### **Tables**

- For creating custom scaling functions.

### **Custom Units**

- Eight analog engineering units.
- Eight binary engineering units.
- Eight multistate units with eight states.

### **SMART-Net Port**

- Network up to eight SMART-Net devices.

### **64 Net Ins**

- The maximum number of shares from other devices.

### **32 Net Outs**

- The maximum number of writes to other devices.

### **Warranty**

- 5 years.

## Typical object configuration

There are physical limitations on the number of inputs, outputs, and SMART-Sensor devices you can connect to your controller. For other object types, create up to 128 objects of a single type. The total number of objects, including inputs, outputs, and SMART-Sensor devices, is limited to 160 and also limited by the onboard memory. The table below details typical databases that fit in all models.

Variables	Loops	Schedules	Calendars	Tables*	Groups	Multipoint Trend**	Runtime	Arrays	Program	SMART-Sensor devices
64	8	4	2	4	4	10	128	4	16	4

\* Runtime reports and tables are not counted in the 160 object limit. Inputs and outputs are counted in the 160 object limit.

\*\* Trends are configured to store 128 samples.

## Product models and accessories

For the most complete, up-to-date information, click your product on the [Products](#) page to access the submittal sheet.

### MPZ-44

- MACH-ProZone with four inputs and four outputs.

### MPZ-48

- MACH-ProZone with four inputs and eight outputs.

### MPZ-84

- MACH-ProZone with eight inputs and four outputs.

### MPZ-88

- MACH-ProZone with eight inputs and eight outputs.

### Options

- -C adds capacitor backup for the real-time clock.

### Build Your Order

To create the order number, add your options to the base model. For example, MPZ-84-C is the order number for a MACH-ProZone with eight inputs, four outputs, and capacitor backup for the real-time clock.

## Accessories

### MPZ-DL-LASER

- MACH-ProZone door label sheet for laser printer.

## KN-JB4

- Package of 10 four-position insulated jumper bars.

## Standard applications

Standard applications for Reliable Controls products are available in the **Engineer** tab in the Reliable Controls Support Center.

Each standard application contains the elements needed to deploy an application, such as:

- Control-BASIC code.
- Panel Files.
- System Groups.
- Annotated sequences of operation.

Standard applications can also serve as useful learning tools to increase your knowledge of different product applications and Control-BASIC programming.

Search the library of existing standard applications or use the Standard App Builder to find a standard application that meets your selection criteria. If you cannot find a standard application that suits your needs in the Standard App Builder, you can request it by clicking the **Submit a request** button.

Download and install the standard application and modify as necessary for your specific implementation.

## MACH-ProZone topologies

The MACH-ProZone can be incorporated into different building control network topologies.

### MACH-ProZone with SMART-Sensor

In this diagram, a MACH-ProZone has inputs and provides solid-state relay or Universal outputs. A SMART-Sensor provides temperature information and allows users to modify setpoints and other area controls. The RJ11 SMART-Net port is connected to an X-Port-2 to configure the controller or view information using Reliable Controls software.

**Note:** You can also connect a SMART-Sensor configured as an MSet Tool to the SMART-Net port to configure the controller.

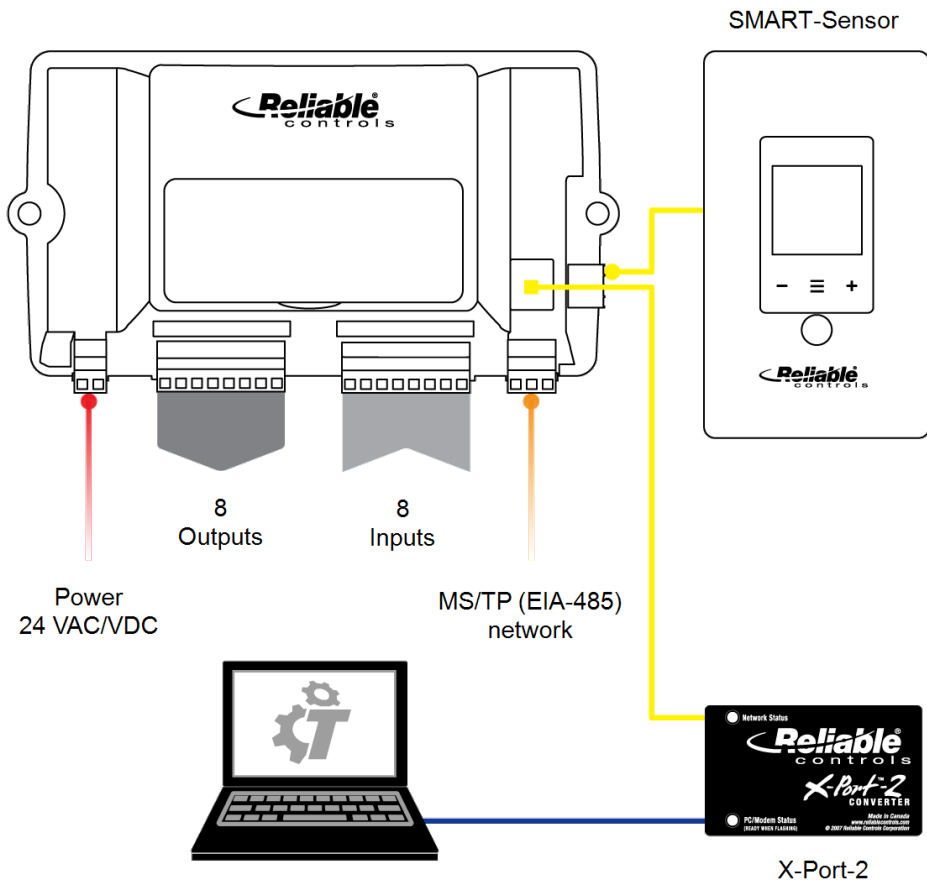

Figure 1: MACH-ProZone-88 with inputs, outputs and a SMART-Sensor with Electronic Paper Display.

## MACH-ProZone in a BACnet MS/TP network

In this diagram, multiple MACH-ProZone controllers are connected to a host Reliable Controls BACnet controller (MACH-ProSys) to create a building control network.

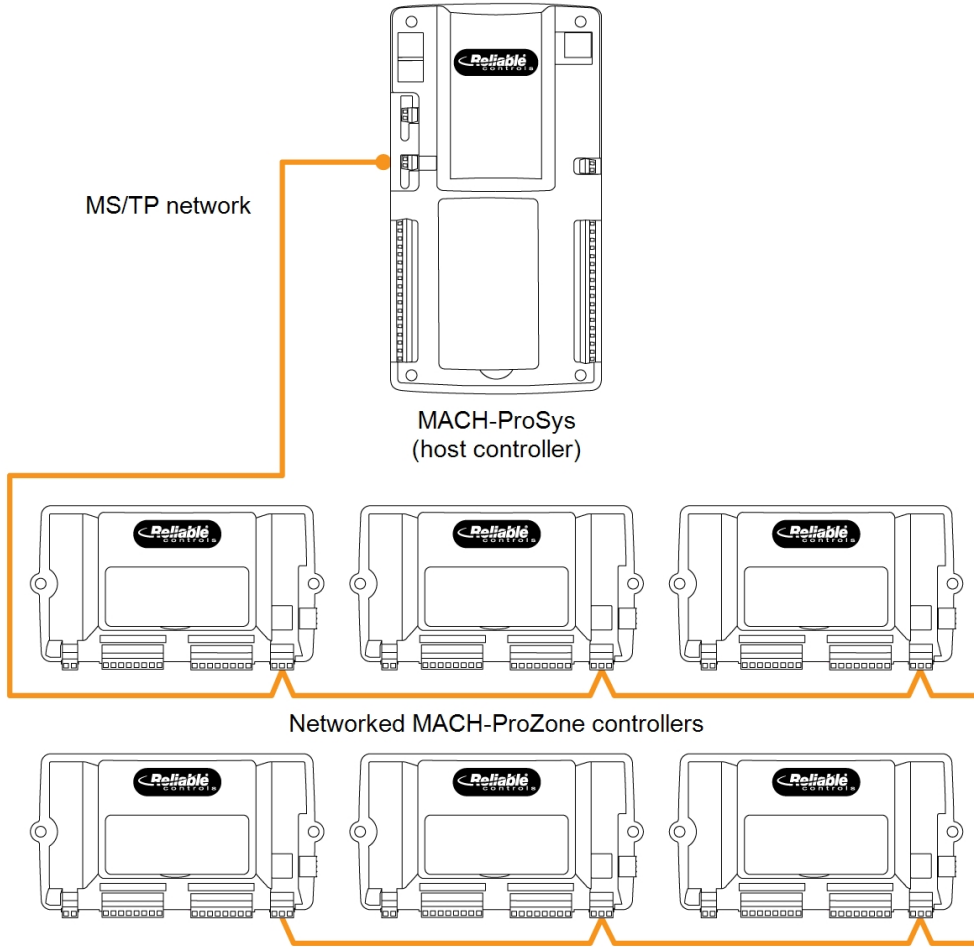

Figure 2: MACH-ProZone MS/TP network with MACH-ProSys controller

## MACH-ProZone with SMART-Net devices

In this diagram, a MACH-ProZone is supporting eight SMART-Sensor devices that run two connections off the 4-pin SMART-Net connector. Signal loss is minimized by placing the controller in the center of the network.

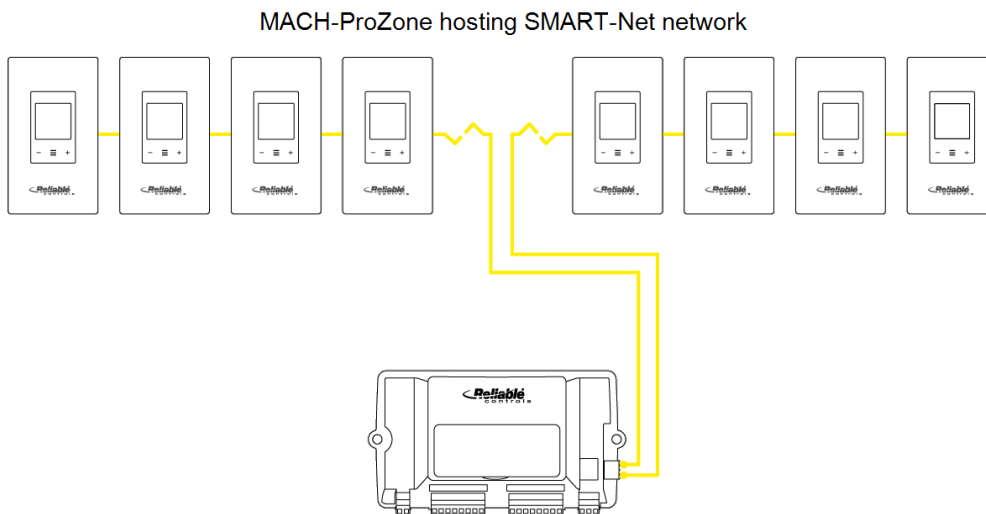

Figure 3: MACH-ProZone with SMART-Sensor devices

## MACH-ProZone hardware overview

Install the MACH-ProZone by connecting power, communications and inputs/outputs.

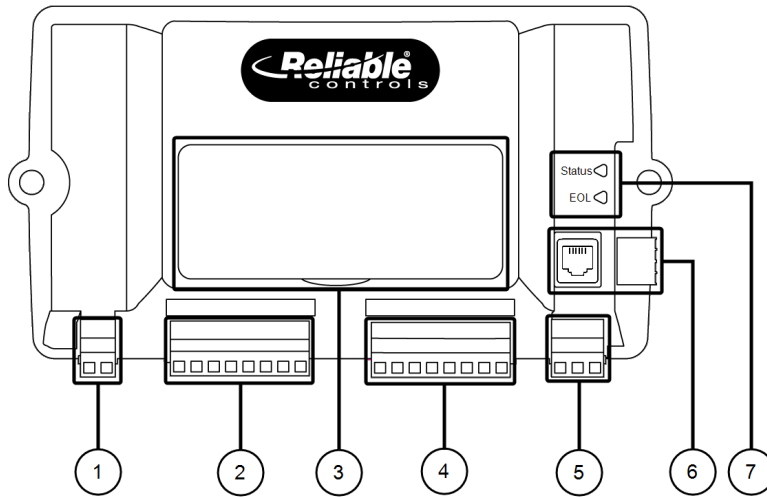

Figure 4: MACH-ProZone connections

- ① Power
- ② Outputs
- ③ End-of-Line (EOL) switch and output jumpers located under cover
- ④ Inputs
- ⑤ EIA-485
- ⑥ SMART-Net
- ⑦ EOL and Status LEDs

## Additional resources

Additional resources are available on the [Reliable Controls Support Center](#).

Click any of the following in the menu bar:

### Products

View all product documentation, manuals, and marketing material.

### Technical

View Release Notes, Bulletins, Product and Security Alerts, and the DDC (Direct Digital Control) Glossary.

**eHelpDesk**

Click the eHelpDesk link in the Support Center banner and search or browse solutions, application support articles, and the community forum, or create a support ticket to connect with an agent.

**Training**

Use the Learning Center to view and register for training courses, access eLearning courses and videos, view webcasts, and download manuals.

# MACH-ProZone installation and wiring

The installation and wiring section describes connecting the power, inputs and outputs of your controller as well as the overall installation process and important considerations.

For more information about wiring and installing Reliable Controls products, refer to the product documentation and the *Hardware Installation Manual*, available in the [Reliable Controls Support Center](#).

## Installation considerations

All Reliable Controls devices must be installed in accordance with the National Electrical Code (NFPA 70), the Canadian Electric Code Part 1 (CSA C22.1-12), or the International Electrical Code (IEC 60730-1) as applicable and in a manner acceptable to the local authority having jurisdiction.

This device is for use in UL Class 2 and Class 3 ELV circuits only.

Follow these guidelines when you install Reliable Controls products:

- Ground yourself before you touch any electronics by touching a grounded metal surface to discharge static electricity.
- Use copper conductors only.
- Choose wires and cables appropriate for your application or installation requirements, for example, plenum-rated material.

## MACH-ProZone power

Your MACH-ProZone must be correctly wired to an appropriate power supply.

### Supply Voltages

- 24 VAC  $\pm$ 10% 25 VA maximum, 50/60 Hz.
- 24 VDC  $\pm$ 10% 12 W maximum.

### Terminal Blocks

- 16–28 AWG.
- Stranded or solid core.
- Copper conductors only.

To determine the size of the AC transformer or DC power supply required for your installation, use the power calculator at [reliablecontrols.com/support/engineer/calculator.php](https://reliablecontrols.com/support/engineer/calculator.php).

## Grounded power

Follow these guidelines when you select and wire the grounded power supply:

- Use a UL Class 2 or Class 3 ELV 24 VAC/VDC power supply for the controller.
- Ensure that all controllers are connected to earth ground.
- To determine the size of the AC transformer or DC power supply required for your installation, use the power calculator at [reliablecontrols.com/support/engineer/calculator.php](https://reliablecontrols.com/support/engineer/calculator.php).

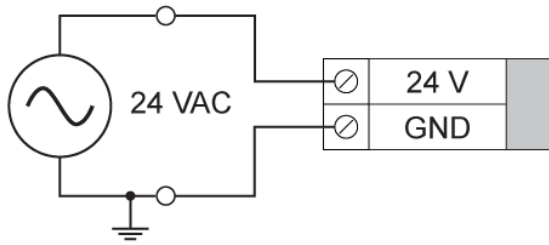

Figure 5: 24 VAC grounded power supply wiring

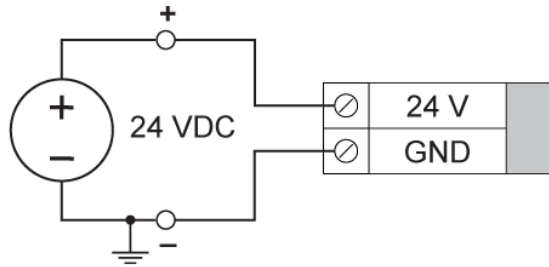

Figure 6: 24 VDC grounded power supply wiring

## MACH-ProZone SMART-Net

Your controller has a SMART-Net four-pin terminal block to support a network of SMART-Net devices.

### Communication Options

- One EIA-485 (RS-485) port that supports a baud rate up to 76.8 Kbps. Auto-baud detection.
- Two SMART-Net ports, one RJ11 and one 4-wire terminal block, that support up to eight devices.

### Terminal Blocks

- 16–28 AWG.
- Stranded or solid core.
- Copper conductors only.

If only the removable four-pin connector is used for the SMART-Net network, the controller's SMART-Net port is available for a workstation connection using an X-Port-2 converter.

## SMART-Net four-pin terminal

Use the removable SMART-Net four-pin terminal block to wire and connect a network of SMART-Net devices.

**Note:** The maximum tested SMART-Net cable length from the host controller to the last SMART-Net device on the SMART-Net bus is 45 m (147 ft). With an externally powered SMART-Net Expansion Board or SMART-Sensor Expansion Board located at the network midpoint, the maximum tested SMART-Net cable length from the host controller to the last SMART-Net device on the SMART-Net bus is 75 m (246 ft).

The SMART-Net network provides power and communications for SMART-Net devices. Reliable Controls recommends 24 AWG (0.21 mm<sup>2</sup>), low capacitance < 82 pF/m (25 pF/f), solid core minimum Category 3 cabling for SMART-Net networks.

Directly connect the SMART-Net four-pin terminals from the controller to the four-pin terminal block on a SMART-Net device, matching the terminals.

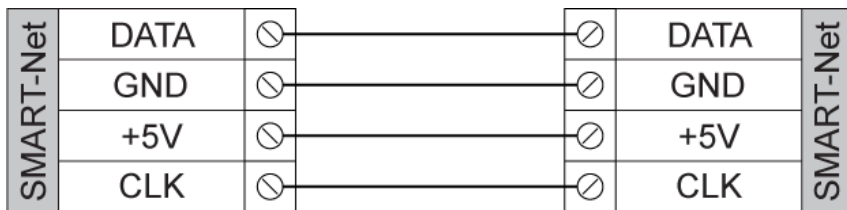

Figure 7: SMART-Net four-pin connection

For detailed information about SMART-Net networks, sensors, and controllers, refer to the SMART-Net device documentation available in the [Reliable Controls Support Center](#).

## SMART-Net RJ11

Your controller's SMART-Net RJ11 port supports a network of SMART-Net devices and MS/TP communications.

The SMART-Net network provides power and communications for SMART-Net devices. Reliable Controls recommends 24 AWG (0.21 mm<sup>2</sup>), low capacitance < 82 pF/m (25 pF/f), solid core Category 3 or Category 5 cabling for SMART-Net networks.

**Note:** The maximum tested SMART-Net cable length from the host controller to the last SMART-Net device on the SMART-Net bus is 45 m (147 ft). With an externally powered SMART-Net Expansion Board or SMART-Sensor Expansion Board located at the network midpoint, the maximum tested SMART-Net cable length from the host controller to the last SMART-Net device on the SMART-Net bus is 75 m (246 ft).

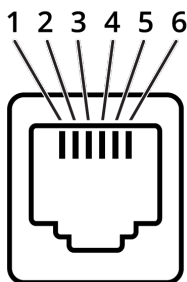

Figure 8: SMART-Net RJ11 port pinout

Table 1: SMART-Net port pinout

Pin	Controller RJ11 port	SMART-Net device RJ11 port	EIA-485
1	Clock	Data	N/A
2	+5 V	Ground	N/A
3	MS/TP A(-)	N/A	MS/TP A(-)
4	MS/TP B(+)	N/A	MS/TP B(+)
5	Ground	+5 V	N/A
6	Data	Clock	N/A

## MACH-ProZone MS/TP network

### Communication Options

- One EIA-485 (RS-485) port that supports a baud rate up to 76.8 Kbps. Auto-baud detection.
- Two SMART-Net ports, one RJ11 and one 4-wire terminal block, that support up to eight devices.

### EIA-485 wiring for grounded controllers

The grounded controller's EIA-485 port is a two- or three-pole terminal block used for BACnet MS/TP communication. The EIA-485 transceiver is non-isolated and internally references the controller's power ground. The ground connection helps keep all networked devices at the same reference to each other which works to improve communications by making sure that signals are at the same level at all nodes throughout a distributed system.

All devices on the same EIA-485 network must communicate using the same protocol and baud rate, and each node must have a unique address. EIA-485 devices are connected using a line topology.

**Note:** Maximum EIA-485 segment length: 1,220 m (4,000 ft).

The grounded controller's EIA-485 terminal block has either two terminals: A(-) and B(+), or three terminals: A(-), B(+), and REF. To connect multiple grounded controllers, use the EIA-485 connector to

wire terminal A(-) to A(-), and B(+) to B(+). Connect the bare shield wires at each junction to help suppress noise along the cable length.

The REF terminal is internally connected to the controller's power ground and can be used to connect isolated devices that use a three-wire MS/TP network.

Installation guidelines:

- Use a good quality, low-impedance, twisted two-conductor shielded communications cable with capacitance less than 82 pF/m (25 pF/ft).
- EIA-485 cable shields should be continuous, electrically connected, and grounded at one end only.
- End-of-Line (EOL) must be set to on for the two devices located at the physical extremities.
- REF terminal is intended to connect isolated devices that use a three-wire MS/TP network.

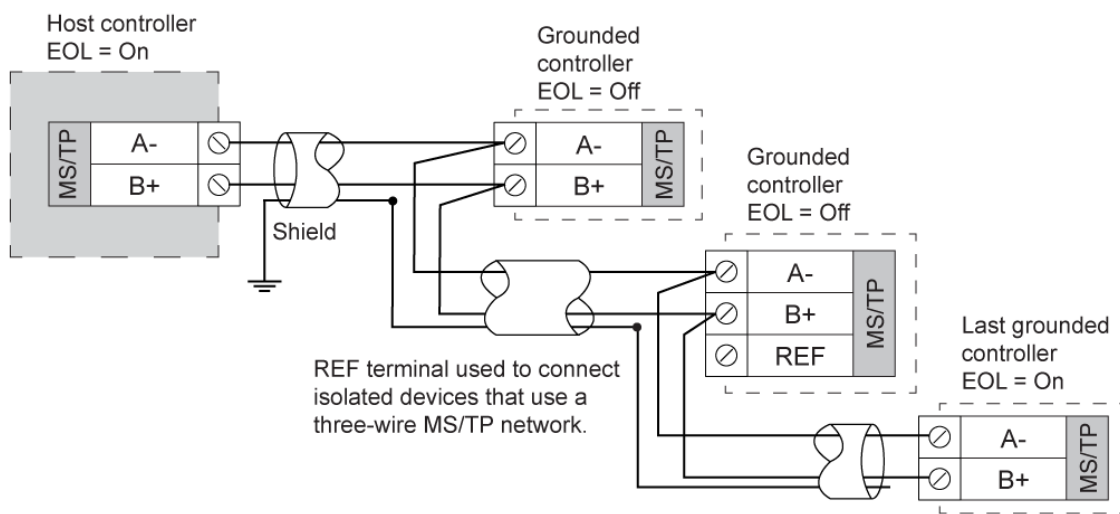

Figure 9: EIA-485 wiring for grounded controllers

## End-of-Line switch

The End-of-Line (EOL) switch must be set to on for the two devices located at the physical extremities of each separate EIA-485 network.

Each EIA-485 network can have only two EOL terminations. EOL switches prevent reflected noise and bring network voltage to a known value if communications are idle. If the network is not terminated correctly, the controller may fail to network properly. If the EOL device is not a Reliable Controls controller, you can add an NA-EOL terminator, available in eBusiness in the Reliable Controls Support Center.

To maintain EIA-485 network integrity, use only Reliable Controls EOL switches or terminators.

## End-of-Line (EOL) LED

The controller has an EIA-485 End-of-Line (EOL) LED that illuminates amber when the controller's EOL switch is on.

## Status LED and network protection

The controller includes a Status LED located near the SMART-Net port that illuminates green or red depending on the controller and communication status.

The Status LED indicates the controller's status as follows:

Status LED	Status
Off	No power. The device is not operating.
Green Flicker	The device is operating and communicating.
Green On 0.5 sec / Off 0.5 sec	The device is operating but not communicating.
Green On 1 sec / Off 1 sec	The device has factory default communication settings. Configure the device using the MSet tool in RC-Toolkit.
Green 4 flashes: On 0.5 sec / Off 0.5 sec Off 1 sec	The device does not have firmware loaded. Load firmware using the OS Send tool in RC-Toolkit.
Red On solid	EIA-485 network issue detected. Common EIA-485 issues are: <ul style="list-style-type: none"> <li>• Power polarity (24 VAC/DC and ground) have been reversed.</li> <li>• Floating ground or different ground potential between two network devices.</li> <li>• Device is not connected to earth ground.</li> <li>• 24 VAC/DC incorrectly applied to the EIA-485 network.</li> </ul>

### EIA-485 protection

The controller uses automatically resetting polyfuses for EIA-485 network protection.

## MACH-ProZone inputs

Your MACH-ProZone has software-configurable universal inputs. The number of inputs varies based on the controller model.

## Universal Inputs

- 12-bit A/D converter.
- Use software to select thermistor/dry contact, 4–20 mA, or 0–10 VDC.
- Impedance:
  - 3 M $\Omega$  on 0–10 VDC range.
  - 250  $\Omega$  on 4–20 mA range.
  - 20 k $\Omega$  on thermistor range.
- Pulse counting up to 40 Hz. Supports flow meters.
- 24 VAC overvoltage protection.

## Terminal Blocks

- 16–28 AWG.
- Stranded or solid core.
- Copper conductors only.

## Inputs

Connect a dry-contact digital, thermistor, 0-10 VDC analog, or 4–20 mA analog input to the controller input terminals as shown in the following input-type schematics:

**Note:** You can also use dry-contact inputs for pulse-counting applications; for example, flow and energy meters.

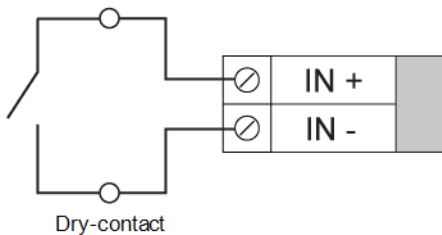

Figure 10: Dry-contact digital input wiring

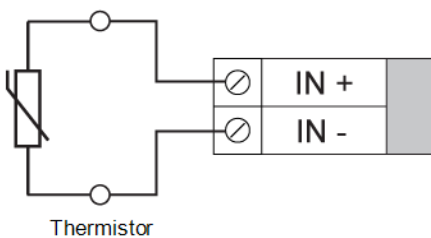

Figure 11: Thermistor wiring

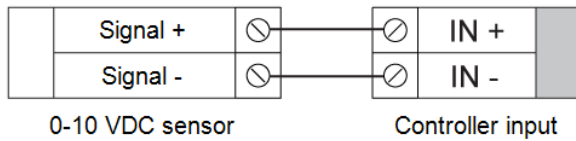

Figure 12: 0–10 VDC analog input wiring

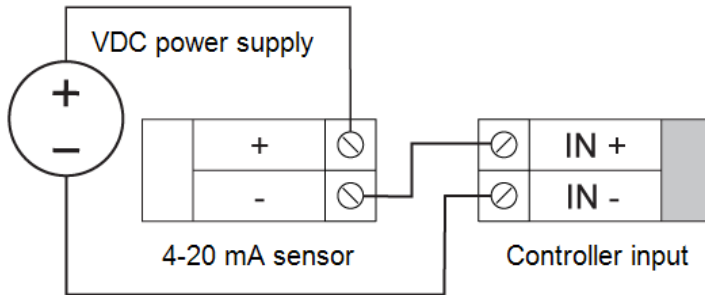

Figure 13: 4–20 mA analog input with external DC power supply wiring

**Note:** 4–20 mA loop-powered sensors require a DC voltage power supply to operate. The controller converts this input to a 1-5 VDC signal. If you scale this input in RC-Studio, the input range of the table is 1-5 VDC.

## MACH-ProZone outputs

The number of supported outputs is defined by the MACH-ProZone model.

### Universal Outputs

- 12-bit D/A converter.
- Analog: 0–12 VDC.
- Binary: Software configurable between 0–12 VDC.
- Output power: 75 mA at 12 VDC.
- 24 VAC overvoltage and short protection.
- Use jumper to select solid-state relay.

### Solid-State Relay Outputs

- Switch 24 VAC/VDC.
- 500 mA maximum.

### Terminal Blocks

- 16–28 AWG.
- Stranded or solid core.
- Copper conductors only.

## Output jumpers

Output jumpers set the output type to send information as either universal or solid-state relay. Configure the jumper before you wire the controller's outputs and before you apply power to the controller.

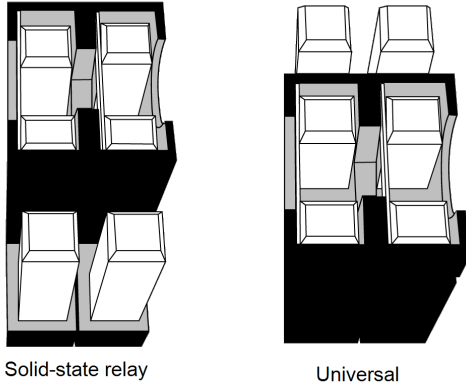

Solid-state relay

Universal

### Set the output jumpers

Use the output jumper to set the output type to match the connected field device or sensor.

To set the output jumpers:

1. Access the internal circuit board.
2. Identify the output jumper that corresponds to the output you want to set.
3. Use the protector director on the circuit board to confirm, or change the jumper position to set the output to the desired input type.

**Note:** The metal strip in the square output jumper block must be vertically aligned. Installing the jumper with the metal strip horizontally aligned causes incorrect output operation.

### Solid-state relay outputs without R~ terminal

Connect the required external 12–24 VAC/VDC power source to the load and complete the wiring to the output terminals as shown.

The voltage supplied at the OUT+ terminal is transferred to the OUT- terminals to power the output loads.

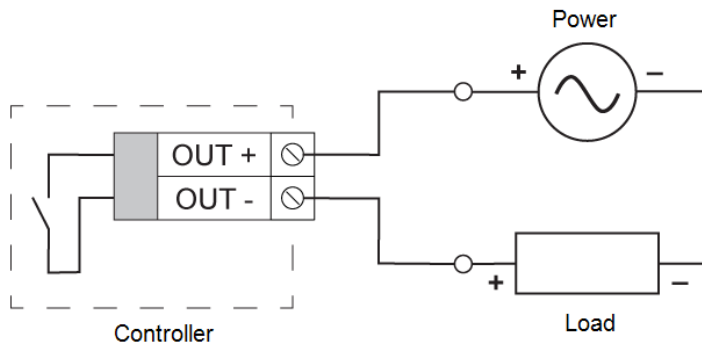

Figure 14: Solid-state relay wiring

## Universal outputs

Connect a relay, digital, or analog output device to your controller's output terminals.

Use software to configure universal outputs as digital or analog.

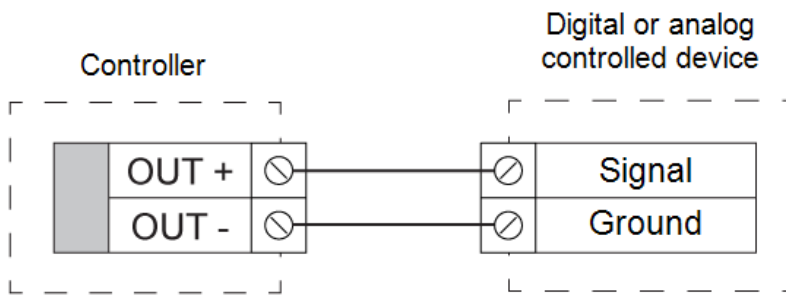

Figure 15: Universal output wiring

## Install the MACH-ProZone

The MACH-ProZone is designed to be mounted in a vertical electronics enclosure.

The controller may be attached to the enclosure by screwing the controller directly to the backplate, or by snapping the controller to a previously installed standard 35 mm (1 3/8") DIN rail. The controller mounting holes are 1.9 cm (3/4") in depth.

# Configuration

Configuration describes how to connect to the controller for the first time.

Once you establish the initial connection, you can configure network communications options that take full advantage of the controller's networking capabilities, and connect with other Reliable Controls software products to configure, view and manage your controller.

The MACH-ProZone only supports the BACnet protocol.

## RC-Toolkit and your controller

Use RC-Toolkit to configure your controller's communications features and to upgrade controller firmware.

Upgrade RC-Toolkit to the latest release to support new features, improvements, and fixes.

RC-Toolkit has several tools for basic controller setup and troubleshooting:

- **MSet:** Use to set your controller's network and communication parameters.
- **OS Send:** Use to update your controller's firmware.
- **Network Diagnostics:** Use to view diagnostics for your controller to troubleshoot network issues.

RC-Toolkit includes the Panel File Utility, a separate program used to read and edit Panel Files and to rapidly duplicate and modify Panel Files to load to your controller.

## Default user access settings

The factory-default user access settings used to log in to the system are stored in the host controller:

- **User:** longview.
- **Password:** Empty, no entry.

For BACnet network security best practices, refer to the *Reliable Controls Hardening Guide*, available in the Engineer tab in the [Reliable Controls Support Center](#).

## Default MS/TP settings

The controller ships with the following default EIA-485 MS/TP settings:

- **BACnet device ID:** Not set.
- **EIA-485 baud rate:** Auto-detect.
- **End-of-Line switch:** Off.

## Initial MS/TP connection

You need to make an initial connection to your controller to configure its network settings.

Use one of the following methods to make the initial connection:

- Use RC-Toolkit to discover your controller after connecting to an existing BACnet MS/TP network. The existing MS/TP network must contain at least one Reliable Controls host controller that can route network traffic.
- Use an RC-Toolkit connected host controller to discover your controller that is not part of a BACnet network.
- Use an X-Port-2 Converter to establish MS/TP-Net communications between a workstation running Reliable Controls software and the controller.
- Use a SMART-Sensor EPD in MSet Tool mode or a SETUP-Tool to connect to your controller's SMART-Net port and program its BACnet MS/TP network settings.

## Connect to an existing MS/TP network

This procedure describes how to use RC-Toolkit to discover the new controller after connecting it to the MS/TP port of a host controller in an existing BACnet MS/TP network.

The following features let you add one or more new controllers to an existing MS/TP network without causing network conflicts:

- **Auto-Baud:** The controller senses the network baud rate and automatically configures itself to communicate at the same rate.
- **Undefined device ID:** The controller ships with undefined BACnet device ID and MAC, so you can add new units to an MS/TP network without creating address conflicts.

To connect to the new controller:

1. Run RC-Toolkit, and connect to the BACnet network that contains the host controller.
2. In the System Tree, right-click the top node, then click **Rediscover Network**.  
Any new devices are populated as nodes in the System Tree.
3. Use the **MSet 1** tool to select the controller and configure its communications settings.
4. Click **Send**  to save the changes to your controller.

You can now connect to your controller using RC-Studio to manage, program, and view your controller information.

## Direct connect to controller using X-Port-2

Use the X-Port-2™ Converter to establish MS/TP-Net communications between a workstation running Reliable Controls software and the controller.



Figure 16: Computer connection to the controller's SMART-Net and MS/TP ports using the X-Port-2

1. Determine the cable you need, based on the type of SMART-Net port available on your controller:

Controller SMART-Net port type	eBusiness part #	Controller connections
RJ11 socket	SS-VC-C	RJ11 connector to the controller's SMART-Net RJ11 socket
5.0 mm 4-pin terminal socket	CC-MULTI-XP2	2-wire 5.0 mm connector to the controller's MS/TP-Net 2-pin terminal socket 4-wire 5.0 mm connector to the controller's SMART-Net 4-pin terminal socket
3.5 mm 4-pin terminal socket	CC-MULTI-XP2	2-wire 3.5 mm connector to the controller's MS/TP-Net 2-pin terminal socket 4-wire 3.5 mm connector to the controller's SMART-Net 4-pin terminal socket

2. Insert the cable's RJ11 plug to the X-Port-2 Converter's SMART-Net port, then connect the other end to the controller.  
The Network Status LED flashes.
3. Wait until the PC/Modem Status LED on the X-Port-2 flashes once per second.  
This indicates the communications connection from controller to X-Port-2 is established.
4. Connect the workstation's USB port to the X-Port-2 Converter's PC/Modem port using the CNV-USB-232 (USB to DB9) adapter cable, CC-C1-B (DB9 to RJ11) adapter base and CC-C1-C (RJ45 data) cable.
5. Open Microsoft Windows Device Manager and identify the COM port number corresponding to the USB port that is connected to the adapter cable.
6. Open RC-Toolkit, click **Options > Communications Preferences**.
7. Under Direct set the **Port** to the same COM port number as above.
8. Click Direct Connect ➡ to initiate communications between RC-Toolkit and the controller.

**Note:** You can purchase adapters, cables and accessories from eBusiness.

## Set up MS/TP communications using RC-Toolkit

Use the RC-Toolkit MSet tool to configure networking options for your controller.

To configure MS/TP communications using RC-Toolkit:

1. Run RC-Toolkit, and connect to a system.
2. Click **MSet 1** , and select your controller in the System Tree. The MSet configuration interface displays.
3. Select and configure the following minimum communications parameters on your controller:
  - **Address:** The MAC, or serial network address, of your controller.
  - **Device ID:** The unique identifier for your controller in the BACnet system.
  - **Device Name:** The descriptive name of your controller.

**Note:** If you select the **Device ID Auto Fill** checkbox, the device ID is automatically filled in when you enter the address. The device ID = base address + address.

4. Select and configure any additional parameters on your controller.
5. Click **Send**  to save the updated parameters to your controller.

### Non-router MS/TP controller MSet

The non-router MS/TP controller MSet worksheet view applies to the following controllers:

- MACH-ProAir
- MACH-ProLight
- MACH-ProZone
- MS/TP only (-M) model MACH-ProView
- MS/TP only (-M) model RC-FLEX controllers
- SMART-Space Controller

To open the MSet worksheet for the controller:

1. Select the MS/TP network and expand it to view the controllers.
2. Click a controller to open its MSet worksheet.

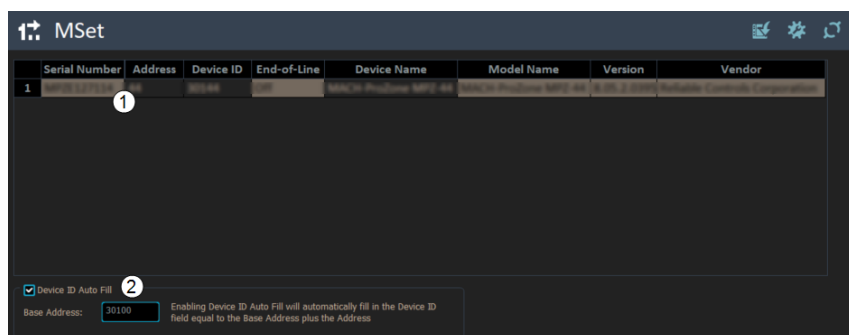

### Actions

#### Print

Prints the IP network configuration worksheet to a document or printer.

### Network Configuration

Opens the BACnet Network Configuration dialog box.

### Broadcast Host Number to Subnetwork

Opens the Broadcast Host Number to Subnetwork dialog box, where you enter the host number and destination subnetwork.

### Set Master Password

Changes the default master password stored in all Reliable Controls system controllers. This option is only available when you sign on with the Master Password.

## ① MS/TP networked devices

### Serial number

The device serial number. This is for information only and cannot be configured.

### Address

The MS/TP address, also referred to as the MAC #, of the device on the network. The address must be unique for each device on the MS/TP network and range from 1 to 127, except for the SMART-Space Controller, where the range is 1–254. Devices that do not have an assigned address temporarily use the value entered in the Configuration MAC box.

### Device ID

The BACnet device ID must be a unique number on the BACnet internetwork, limited to between 1 and 4,194,302. When you select **Device ID Auto Fill**, the device ID defaults to the base address plus the address.

### End-of-Line (EOL switch)

Displays the status of the device's End-of-Line (EOL) switch. The EOL switch for all devices communicating on the same MS/TP network should be Off, except for the last device at the physical end of the EIA-485 network—that device's EOL switch should be the only one that is On. For RC-FLEX MS/TP devices, click the End-of-Line cell to toggle the switch On or Off. N/A indicates the End-of-Line property for that device is unknown or not available.

**Note:** Do not use device ID 0. Using zero can cause issues with older BACnet software and zero is not supported by RC-Studio.

### Device Name

By default, the device name is the device model name. You can change the device name to be more useful for your implementation. For example, name the device according to the building area or room number where it is located.

### Model Name

The device model name. This is for information only and cannot be configured.

### Version

The version of firmware currently running on the device. This is for information only and cannot be configured. Use OS Send to upgrade Reliable Controls device firmware.

## Vendor

The BACnet device vendor. Use RC-Toolkit to configure Reliable Controls devices only.

## ② Device ID Auto Fill

For controllers not configured with a value in the Device ID column, if you select **Device ID Auto Fill**, RC-Toolkit generates the device ID based on the value in the Address column and the value entered in the Base Address box.

## Base Address

Enter the base address used to automatically generate device IDs.

## Set up MS/TP communications using the SMART-Sensor MSet Tool

Use the SETUP-Tool or a SMART-Sensor EPD (SS3-E) in MSet Tool mode to configure communications on a Reliable Controls controller.

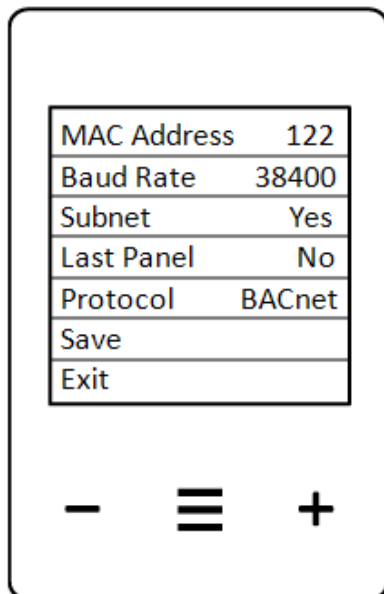





Figure 17: SMART-Sensor EPD in MSet Tool mode

To put a SMART-Sensor EPD in MSet Tool mode and configure your controller:

1. Connect the SMART-Sensor to the controller's SMART-Net port.
2. Hold **−** and **+** for 5 seconds and then release.
3. Wait for 2 seconds.
4. Tap **−**.  
The Dealer Menu appears.
5. In the Dealer Menu, use **list** **≡** to select the **MSet** row.
6. Tap **+** to enter the MSet Tool menu.

7. In the MSet Tool menu, tap **list**  to select the next configurable parameter. Use **—** and **+** to modify parameters.
8. Tap **list**  to select the **Save** row.
9. Tap **+**.  
The SMART-Sensor sends the modified parameters to the controller.
10. Tap **list**  to select the **Exit** row.
11. Tap **+** to return the SMART-Sensor to normal operation.

**Note:** For more information about the SMART-Sensor and MSet Tool, see the SMART-Sensor product documentation, available from the Reliable Controls Support Center.

## Baud rate configuration

The controller is factory-set with the baud rate set to auto-detect so you can easily add it to an existing MS/TP network.

When you configure your controller over an MS/TP network, part of that configuration should include setting a fixed baud rate. Use the MSet tool in RC-Toolkit to set the baud rate for all devices on the network. Some devices allow you to set the baud rate on each device individually.

**Note:** You cannot set the baud rate on an individual MS/TP-only controller; instead you must use the MSet tool in RC-Toolkit to set the baud rate for all devices on the MS/TP-Net network.

## How auto-detect works

When the controller powers up in auto-detect mode, it listens on the default baud rate of 76800 for valid MS/TP communication.

- If the controller detects a valid MS/TP frame, which indicates an active, functioning MS/TP network, it starts normal MS/TP communications at that baud rate.
- If the controller detects invalid network activity, it waits for a period of time, then goes back through the auto-detect process of listening on the different baud rates for valid MS/TP network communications.
- If the controller does not detect valid MS/TP communications, the controller goes to the next lowest baud rate to listen for valid MS/TP communications.
  - If the controller cycles through all the baud rates and does not detect any valid MS/TP communication, it returns to the default baud rate and listens to determine its next action.
  - If the controller does not detect any network activity for a set period of time, it assumes it is the only manager on the network. The controller generates its own token and communicates over MS/TP at the default baud rate.

## Why set a fixed baud rate?

If you have a simple MS/TP network, with short cable runs and devices with similar power-up durations that operate at the default baud rate of 76800, you may not have any issues with leaving your device's baud rate in auto-detect.

If you have a complex MS/TP network, with subnetworks, long cable runs, and devices with different power-up durations from different manufacturers that do not operate at the default baud rate of 76800, setting a fixed baud rate helps your MS/TP network recover from a power cycle or reset.

Auto-detect can cause MS/TP network issues if the following conditions are present:

- If the device that defines the network's baud rate—the baud manager—has a long power-up duration, during the delay the other devices on the network define the network's baud rate and start communicating. If the baud rates are different, the baud manager can't communicate on the MS/TP network.
- If the network has long and noisy cable runs, devices in auto-baud always detect network errors. This can put auto-baud devices in a condition where they continuously cycle through the different baud rates, but because they do not find any valid MS/TP communications, they cannot detect the correct network baud rate.

For more information, refer to *Application Notice 14, EIA-485 Wiring Types*, and *Application Notice 20, Troubleshooting EIA-485 Networking Problems*, available on the [Reliable Controls Support Center](#).

For these reasons, Reliable Controls recommends setting a specific baud rate on all MS/TP networked devices.

**Note:** Use RC-Toolkit to send a network configuration message that sets the baud rate for all devices on the MS/TP network.

## Identify and troubleshoot auto-detect baud rate issues

Observe the controller's status LED. If it is flickering green, it is communicating normally on the MS/TP network. If it is green and blinking on/off, there is a network communication issue.

Connect an MSet Tool to the controller to view the current baud rate.

Connect to your network using RC-Toolkit, select an MS/TP device, and select the Network Diagnostics tool. In the Network Diagnostics tool, click **Advanced**, and select **MS/TP** to view information about the MS/TP network. The following list of values can help you identify issues related to auto-detect baud rate settings:

- **Link speed:** The baud rate, which should be the same value for all devices on the MS/TP network.
- **Baud changes :** The number of times the baud rate has changed. If this value is increasing, it could indicate an auto-detect race condition.
- **Total UART errors:** The total number of UART errors. If this value is increasing, it could indicate data at other baud rates on the network.

Refer to RC-Toolkit online help for detailed information about the Network Diagnostics tool.

## MACH-ProZone reset button

The MACH-ProZone's reset button is located on the internal circuit board and is accessed by removing the cover.

### Reset button operation

Use the reset button to clear the controller's Panel File or the controller's Panel File and MSet network configuration.

**Note:** Only use the reset button when absolutely necessary. Read and understand the following material before you use it.

Before you reset your controller, back up your controller's Panel File using RC-Studio. When you reset the controller, all data is cleared on the controller, including configuration and programming.

Reset a controller if you are installing a previously used device in a new location and want to remove all information associated with the previous installation. Resets do not affect the controller's firmware.

The reset button is functional only if you press it while the controller is powered down and keep pressing it while the controller powers up. Pressing the reset button has two possible results, depending on how long you hold it:

- **Database** : Press and hold the reset button, power the controller, and release after two flashes of the status LED, approximately 2 seconds. This operation clears the Panel File from the controller but does not affect network settings such as device ID. The controller's functions are restored if you load an appropriate Panel File.
- **MSet** : Press and hold the reset button, power the controller, and release after 10 flashes of the status LED, approximately 10 seconds. This operation clears the database and restores the controller to its factory defaults, including network configuration settings such as addressing. After an MSet reset, the controller's network settings are cleared, and you must configure it with an address and other parameters to restore communications. The controller's functions are restored when you load an appropriate Panel File.

## Controller database

The MACH-ProZone has firmware that defines the features available on your controller.

The MACH-ProZone is a BACnet-only device that can read and write BACnet object information from other Reliable Controls controllers connected to the network, up to a fixed limit.

The SHARE or SHARE-NET function must be written into a Control-BASIC program running on the MACH-ProZone in order for a MACH-ProZone to share information with a SMART-Space Controller.

Use RC-Studio to configure the operation of your controller.

## RC-Studio and your controller

Use RC-Studio to configure the functions available on your controller. Upgrade to the latest software release for new features, improvements, and fixes.

Use the worksheets in RC-Studio to configure your controller's input and output characteristics and any connected SMART-Net devices. You can also define the controller's objects, such as values, trend logs, loops, and calendars, in RC-Studio worksheets. Create System Groups and write programs in the software to provide a graphical interface to your Reliable Controls system.

The RC-Studio System Tree includes a Network Status worksheet for each network that displays controller information, including the firmware version and available memory.

For more information, refer to the RC-Studio online help. eLearning courses are available through the Reliable Controls Learning Center.

## Point Status BACnet property

Use the Point Status BACnet property to read an object's status as a number value for Control-BASIC programming. The Reliable Controls proprietary BACnet property piPP\_Point\_Status (:1338) returns an enumerated value based on the object and the object's state.

Reliable Controls proprietary BACnet properties are available in eForum on the [Reliable Controls Support Center](#).

This property is included on the following version 8 hardware and firmware controllers:

- MACH-ProAir, MACH-ProZone, MACH-ProLight
- MACH-Pro1, MACH-Pro2
- MACH-ProView
- MACH-Pro(Web)Com/Sys
- RC-FLEX controllers

The following table lists the objects and the enumerated values that describe the object state:

Object type	Enumerated values	Notes
Calendar, programs, inputs, loops, schedules	0: Auto 1: Timed override	Write 0 to this property to return the object to automatic mode.

Object type	Enumerated values	Notes
	2: Manual	
Outputs, values (all types)	0: Auto 1: Timed override 2: Manual 3: Priority override (priority other than 8 or 10) 4: Out of service (outputs only) 5: Overridden HOA off 6: Overridden HOA hand	Write 0 to this property to return the object to automatic mode, clear out of service, and relinquish all priorities except: <ul style="list-style-type: none"> <li>• 1: Life safety</li> <li>• 6: Minimum off/on time</li> <li>• 10: Auto</li> </ul>

## Database storage and configuration

Disconnected from power, your controller can retain data and trend logs for up to 72 hours and data and Trend Logs are retained over a firmware upgrade.

For legacy (version 7) controllers, data and trend logs were not retained over a firmware upgrade.

Version 8 controllers have two levels of database protection in the event of power loss:

- The current database is always preserved for up to 72 hours using a maintenance-free onboard capacitor.
- The current database is backed up every 24 hours to flash (non-volatile) memory.

If more than 72 hours passes without power, the controller uses the backup to restore the database. MACH-ProZone -C models use a replaceable battery for backup, instead of a capacitor, and the battery maintains the clock and database for up to one year.

If you need to remove power for more than 72 hours after making database changes, back up your Panel file, wait one minute for the backup to complete on the controller, and then remove power. The act of backing up the Panel file causes the controller to write the updated database to flash (non-volatile) memory which is retained indefinitely.

### Panel file compatibility

You can directly load legacy (version 7) Panel files onto version 8 controllers without converting them. Modifying a version 7 Panel file in RC-Studio Simulate mode to operate on a version 8 controller converts the Panel file.

A version 8 Panel file cannot be loaded onto a legacy (version 7) controller without being converted. You can convert Panel files using the RC-Toolkit Panel File Utility, which prompts you to identify the objects to retain or remove.

## Supported Control-BASIC

The MACH-ProZone supports a subset of the Control-BASIC statements and functions.

**Note:** If the MACH-ProZone's runtime interpreter comes across a statement or function it does not support, the program exits at that line and sets the Exit status for that program to Yes.

### Supported Control-BASIC statements

The following table lists the Control-BASIC statements supported by the MACH-ProZone:

Alarm/Print	Execution control	Point command	Miscellaneous
ALARM	END	CLEAR	REM
ALARM-TYPE	FOR	CLOSE	
DALARM	IF / IF+ / IF-	ENABLE / DISABLE	
ON-ALARM	GOSUB	IDLE	
	GOTO	LET	
	NEXT	OPEN	
	ON	RELINQUISH	
	RETURN	SET-PRIORITY	
	WAIT	START	
	SHARE	STOP	
	SHARE-NET	WRITE	

The following table lists the Control-BASIC statements that are not supported by the MACH-ProZone:

Alarm/Print	Execution control
APDIAL	CALL
HANGUP	DECLARE
ON-ERROR	
PHONE	
PRINT	
PRINT-AT	
SET-PRINTER	

## Supported Control-BASIC functions

Math		System access	Time
ABS	LSEL	CONPROP	DOM
ARCCOS	MAX	CONRATE	DOW
ARCSIN	MAX-ITEM	CONRESET	DOY
ARCTAN	MIN	POWER-LOSS	INTERVAL
AVG	MIN-ITEM	RAMP	TIME
BIT-SET	SELECT	SCANS	TIME-OFF
BIT-TEST	SIN	SCHED	TIME-ON
COS	SLIDE	SENSOR-OFF	
ENTHALPY	SQR	SENSOR-ON	
FLOAT	SWITCH	TBL	
HSEL	TAN		
INT	LIMIT		
LN	LN-1		

# Specifications

For the most complete, up-to-date information, click your product on the [Products](#) page to access the submittal sheet.

## Processor

- 66 MHz high-performance 32-bit embedded microcontroller with onboard Flash memory.
- Controller database stored in robust nonvolatile memory. Value and log data stored in 3-day battery-backed memory.
- Easily update system firmware at any time over the network.

## Supply Voltages

- 24 VAC  $\pm 10\%$  25 VA maximum, 50/60 Hz.
- 24 VDC  $\pm 10\%$  12 W maximum.

## Communication Options

- One EIA-485 (RS-485) port that supports a baud rate up to 76.8 Kbps. Auto-baud detection.
- Two SMART-Net ports, one RJ11 and one 4-wire terminal block, that support up to eight devices.

## Universal Inputs

- 12-bit A/D converter.
- Use software to select thermistor/dry contact, 4–20 mA, or 0–10 VDC.
- Impedance:
  - 3 M $\Omega$  on 0–10 VDC range.
  - 250  $\Omega$  on 4–20 mA range.
  - 20 k $\Omega$  on thermistor range.
- Pulse counting up to 40 Hz. Supports flow meters.
- 24 VAC overvoltage protection.

## Universal Outputs

- 12-bit D/A converter.
- Analog: 0–12 VDC.
- Binary: Software configurable between 0–12 VDC.
- Output power: 75 mA at 12 VDC.
- 24 VAC overvoltage and short protection.
- Use jumper to select solid-state relay.

## Solid-State Relay Outputs

- Switch 24 VAC/VDC.
- 500 mA maximum.

## Memory and Real-Time Clock Backup (-C Option)

- Capacitor backup maintains clock operation for 72 hours after power loss.
- Real-time clock accurate to  $\pm 1$  second per day.

### **Terminal Blocks**

- 16–28 AWG.
- Stranded or solid core.
- Copper conductors only.

### **Mounting**

- #8 clearance holes on 17.8 cm W (7" W) centerline.
- Option to mount to DIN rail accessory.

### **Dimensions**

- 19.1 cm L x 10.9 cm W x 4.6 cm H  
(7 1/2" L x 4 5/16" W x 1 13/16" H).

### **Ambient Limits**

- Operating: -20°C to 55°C  
(-4°F to 131°F).
- Shipping: -40°C to 60°C  
(-40°F to 140°F).
- Humidity: 10%–90% RH noncondensing.

### **Weight**

- 0.3 kg (0.7 lb).

### **Certifications**

- BTL Listed (B-BC).
- CE.
- CFR 47 Part 15 Class B.
- UL 916 Listed.
- WEEE.